

IRRIGATION WATER AGREEMENT

THIS IRRIGATION WATER AGREEMENT (“Agreement”) is by and between the RENAISSANCE IN THE REDLANDS HOMEOWNERS ASSOCIATION, a Colorado non-profit corporation (the “Renaissance HOA”), and Redlands Three Sixty, LLC, a Colorado limited liability company (“Redlands Three Sixty”). Redlands Three Sixty is the owner of the following real property:

The Renaissance 360 Subdivision, as set forth in the Plat of the Renaissance 360 Subdivision recorded in the records of the Mesa County Clerk and Recorder on October 12, 2020 at Reception No. 2946938, which is comprised of lands in the Northeast Quarter of the Southwest Quarter (NE1/4SW1/4) of Section 18, Township 1 South, Range 1 West of the Ute Meridian in Mesa County, Colorado, containing approximately 39.92 acres (the “Renaissance 360 Subdivision”).

RECITALS

A. Renaissance HOA is the community association described in the Declaration of Covenants, Conditions and Restrictions for Renaissance in the Redlands Filing One and Two recorded in the records of the Mesa County Clerk and Recorder (the “Clerk”) on February 8, 2002 at Reception No. 2039895, (the “Declaration”), as amended. The Renaissance HOA is charged with the governance and operation of the common interest community created by the Declaration (the “Community”) and has all the powers and duties described therein.

B. The lands comprising the Renaissance 360 Subdivision are a separate piece of real estate adjacent to the Community, but not included therein. The Renaissance 360 Subdivision is being separately developed by Redlands Three Sixty.

C. Redlands Three Sixty desires to avoid the expense of constructing facilities for the delivery of irrigation water to Tracts A and C of the Renaissance 360 Subdivision, the locations of which are illustrated in Exhibit 1 attached and incorporated herein, which are to be common elements of the Renaissance 360 Subdivision, and therefore has requested the Renaissance HOA to provide access to irrigation water and use of the Irrigation Facilities, as described herein.

D. Pursuant to Article XIV, Section 14.01 of the Declaration, Renaissance HOA owns and possesses the exclusive right to manage the distribution of irrigation water within the Community and to control, operate and maintain any and all irrigation facilities within the Community for the purpose of delivery of irrigation water.

NOW THEREFORE, in consideration of the mutual benefits to each of the parties, the

receipt and sufficiency of which is acknowledged, the parties agree as follows:

1. Separate Entities. The Renaissance HOA and Redlands Three Sixty each acknowledge and agree that each party is a completely separate legal entity having no claim or control over the acts of the other. Actions taken, liabilities incurred, or benefits obtained by the Renaissance HOA are not binding upon, do not run to or inure to the benefit of Redlands Three Sixty, and actions taken, liabilities incurred, or benefits obtained by Redlands Three Sixty are not binding upon, do not run to or inure to the benefit of the Renaissance HOA. The Renaissance HOA and Redlands Three Sixty and each of them do not by this Agreement intend to create any legal relationship between them other than the relationship specifically described in this Agreement.

2. Definitions.

a. "Irrigation Facilities" means and refers to the Renaissance HOA's presently existing system of head gates, pipes, and other equipment or facilities of every kind, type, nature or description and used to obtain, retain, move, deliver, manage, control or disburse irrigation water from the Redlands Second Lift Canal to the Redlands Three Sixty Tap, including any repairs, upgrades, improvements, or replacements made thereto.

b. "Watering Season" means and refers to the period of time during each calendar year that irrigation water is available for delivery to the Renaissance HOA by the Redlands Water and Power Company ("RW&P") pursuant to the water rights represented by shares in RW&P held by the Renaissance HOA.

c. "Redlands Three Sixty Tap" means and refers to the point from the Irrigation Facilities at which water will be delivered to the Renaissance 360 Subdivision, and its associated valves, vault, pump, and other structures, shown on **I-1 Irrigation Exhibits 2(a) and 2(b)** attached and incorporated herein.

3. Provision of Water. The Renaissance HOA shall provide irrigation water, via the Irrigation Facilities, to Redlands Three Sixty during the Watering Season in such amounts and at such times as is reasonably necessary for the purpose of properly irrigating Tracts A and C of the Renaissance 360 Subdivision, subject only to the potential that irrigation water becomes unavailable from RW&P or that the Renaissance HOA is unable, despite its good faith and reasonable efforts, to obtain irrigation water; provided, however, that the use of water on Tracts A and C of the Renaissance 360 Subdivision shall not be in such large quantity, not to exceed the pro-rata delivery to the water rights represented by two shares of RW&P as to unreasonably interfere with the use of water by the owners in the Community or to require any modification to the Irrigation Facilities, beyond that contemplated by this Agreement, in order to properly provide sufficient water supply. The Renaissance HOA will make good faith efforts to convey such water to the Redlands Three Sixty Tap for use on Tracts A and C of the 360 Subdivision. The Renaissance HOA is responsible for conveying water to the other properties in the Community, provided, however, that the Renaissance HOA shall have no obligation to purchase or otherwise acquire or obtain water rights in addition to those water rights it owns

on the date of this Agreement.

4. Facilities Required. The Redlands Three Sixty Tap and its associated isolation valve shall be installed by Redlands Three Sixty at its sole cost and expense in a good and workmanlike manner pursuant to plans approved by the Renaissance HOA, which approval shall not be unreasonably withheld. Redlands Three Sixty will provide such facilities that will accept and distribute the irrigation water as recommended by its professional landscape architects and engineers, as described in **I-1 Irrigation Exhibits 2(a) and 2(b)**. Redlands Three Sixty will independently comply with the Renaissance HOA's requirements for water storage (vault) and will pressurize its own system at Redlands Three Sixty expense within the Renaissance 360 Subdivision for irrigation of Tracts A and C.

5. Transfer of Shares. In consideration of the obligations of the Renaissance HOA and to facilitate its performance of its obligations, Redlands Three Sixty shall transfer and convey to the Renaissance HOA all rights and interest in two (2) shares in the RW&P represented by Certificate No. 8818 and the water rights represented thereby.

6. Payment by Redlands Three Sixty for Irrigation Water. Redlands Three Sixty agrees to pay the Renaissance HOA an annual fee to cover a portion of the costs of obtaining and delivering irrigation water to the Renaissance 360 Subdivision under this Agreement (the "Irrigation Water Fee"), but (except as provided in Section 8 below) not including any expenses of maintaining the Irrigation Facilities. The Irrigation Water Fee will be calculated by multiplying the RW&P per share annual assessment by 2.1. For purposes of example only, if the RW&P assessment for a year is \$250 per share, the Irrigation Water Fee to be paid by Redlands Three Sixty would be calculated as \$525 ($\$250 * 2.1 = \525). The Renaissance HOA will communicate the Irrigation Water Fee for the upcoming year to Redlands Three Sixty no later than thirty (30) days after the Renaissance HOA is notified by RW&P what the annual assessment by RW&P will be for that year. The Irrigation Water Fee will be paid in full by Redlands Three Sixty not later than thirty (30) days after such notice. Any assessment not paid within thirty (30) days after the due date shall bear interest from the due date at a rate of eighteen percent (18%) per annum.

7. Renaissance HOA Maintenance. The Renaissance HOA, at its sole cost and expense, is responsible for installing, repairing, replacing, improving, or otherwise creating or maintaining the Irrigation Facilities up to the Redlands Three Sixty Tap; provided, however, that the Irrigation Facilities that pertain to or otherwise affect the 360 Subdivision shall not be materially altered or relocated from their existing condition or location without the consent of Redlands Three Sixty. The Renaissance HOA will make good faith efforts to consult with Redlands Three Sixty in any decisions contemplated regarding maintenance to Irrigation Facilities that pertain to or otherwise affect the 360 Subdivision. Redlands Three Sixty will be responsible for all maintenance, repair and replacement of all facilities from the Redlands Three Sixty Tap to the points of use on Tracts A and C within the 360 Subdivision.

8. Maintenance Fee. Redlands Three Sixty agrees to pay the Renaissance HOA a fee, in addition to the Irrigation Water Fee, for a portion of the expenses of the Renaissance HOA

in connection with installing, repairing, replacing, improving, or otherwise creating or maintaining the Irrigation Facilities (the "Maintenance Fee"). The Maintenance Fee will be calculated by allocating to Redlands Three Sixty fifteen percent (15%) of the line item(s) for maintenance of the Irrigation Facilities in the Renaissance HOA's budget for the upcoming year. The Renaissance HOA will communicate the Maintenance Fee for the upcoming year to Redlands Three Sixty. The Maintenance Fee will be paid in full by Redlands Three Sixty not later than thirty (30) days after such notice from the Renaissance HOA.

9. Assignment. It is expressly contemplated that Redlands Three Sixty may assign all rights and obligations under this Agreement to a Colorado non-profit corporation serving as the homeowners' association for the Renaissance 360 Subdivision to which Tracts A and C of the Renaissance 360 Subdivision may be conveyed. The terms of this Agreement will be carried forward unless modified by mutual agreement between the new Colorado non-profit corporation and Renaissance HOA. This agreement is for the sole purpose of providing water conveyance to the common areas within the 360 Subdivision for irrigation of Tracts A and C.

10. Term and Termination. It is intended that the agreement be perpetual, subject to termination as provided in this paragraph. This agreement may be terminated by either party Redlands Three Sixty, or its successor and assignee, on thirty (30) days written notice, subject to the obligations of Redlands Three Sixty to (1) pay all outstanding Irrigation Water and Maintenance Fees, and (2) restoring the "system at the Tap" or by written agreement of the parties. If the Renaissance HOA is the party that unilaterally terminates this agreement, it shall be required to reconvey all interest in and right to the two (2) RW&P shares previously conveyed to it by Redlands Three Sixty.

11. Notices. All notices and other communications required or contemplated by this Agreement shall be given in writing and shall be deemed received when deposited in the mail and sent by first class mail, postage prepaid, to the party at its address set forth below. The parties shall be responsible for notifying each other promptly in writing of any change of address.

If to the Renaissance HOA:

C/O Community Association Mgr
Heritage Property Management
2650 North Avenue, Suite 116
Grand Junction, CO 81501

If to Redlands Three Sixty, LLC:

1755 Telstar Drive, Suite 211
Colorado Springs, CO 80920

12. Waiver. The waiver by either party of a breach or violation of any provision of this Agreement shall not operate as or be construed to be a continuing waiver or a waiver of any subsequent breach of either the same or any other provision of this Agreement.

13. Binding Effect, Integration, and Third Party Beneficiaries. This Agreement is binding upon and inures to the benefit of the parties, their guests, tenants, invitees, designees, successors and assigns. This Agreement constitutes the entire agreement of the parties and

supersedes all previous agreements, written or oral, between the parties. No statement, promise, or inducement made by either party, or the agent of either party, either written or oral, which is not provided for in this Agreement, is binding upon the parties. The parties do not contemplate that there are any third party beneficiaries of this Agreement, and no third parties will be entitled to bring or maintain any action or claim regarding this Agreement in any court or elsewhere.

14. Governing Law, Venue, and Attorneys' Fees. This Agreement shall be construed under and interpreted according to the laws of the State of Colorado. Venue with respect to any litigation arising hereunder shall only be Mesa County, Colorado. In the event that any dispute, claim or litigation arises out of this Agreement, then the prevailing party shall be entitled to recover its reasonable attorneys' fees and all other costs incurred in connection with any such dispute, claim or litigation, whether or not legal proceeding are initiated, including any appeals or petitions, from the other party.

DATED this 17th day of September, 2020.

Renaissance in the Redlands Homeowners Association, a Colorado nonprofit corporation

By: David McIlroy
David McIlroy, President
Name Title

By: Richard Swindle
Richard Swindle, Secretary
Name Title

**REDLANDS THREE SIXTY, LLC
a Colorado limited liability company:**

By: La Plata Communities, Inc., Manager
By: B. Douglas Quimby
B. Douglas Quimby, President
Name Title

STATE OF COLORADO)
) ss.
County of Mesa)

The foregoing instrument was acknowledged before me this 17th day of September, 2020, by David McInay, as President of the Renaissance in the Redlands Homeowners Association, a Colorado non-profit corporation.

Witness my hand and official seal.

My commission expires: June 27, 2023

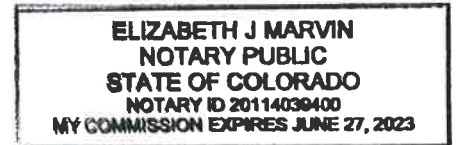

[Signature]
Notary Public

STATE OF COLORADO)
) ss.
County of Mesa)

The foregoing instrument was acknowledged before me this 17th day of September, 2020, by Richard Swayne, as Secretary of the Renaissance in the Redlands Homeowners Association, a Colorado non-profit corporation.

Witness my hand and official seal.

My commission expires: June 27, 2023

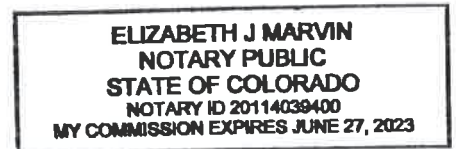

Notary Public

[Signature]

STATE OF COLORADO)
) ss.
County of Mesa)

The foregoing instrument was acknowledged before me this 27th day of October September, 2020, by B. Douglas Quimby as President of La Plata Communities, as Inc., Manager of Redlands Three Sixty, LLC, a Colorado limited liability company..

Witness my hand and official seal.

My commission expires: 8/4/23

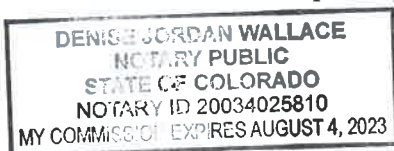

[Signature]
Notary Public

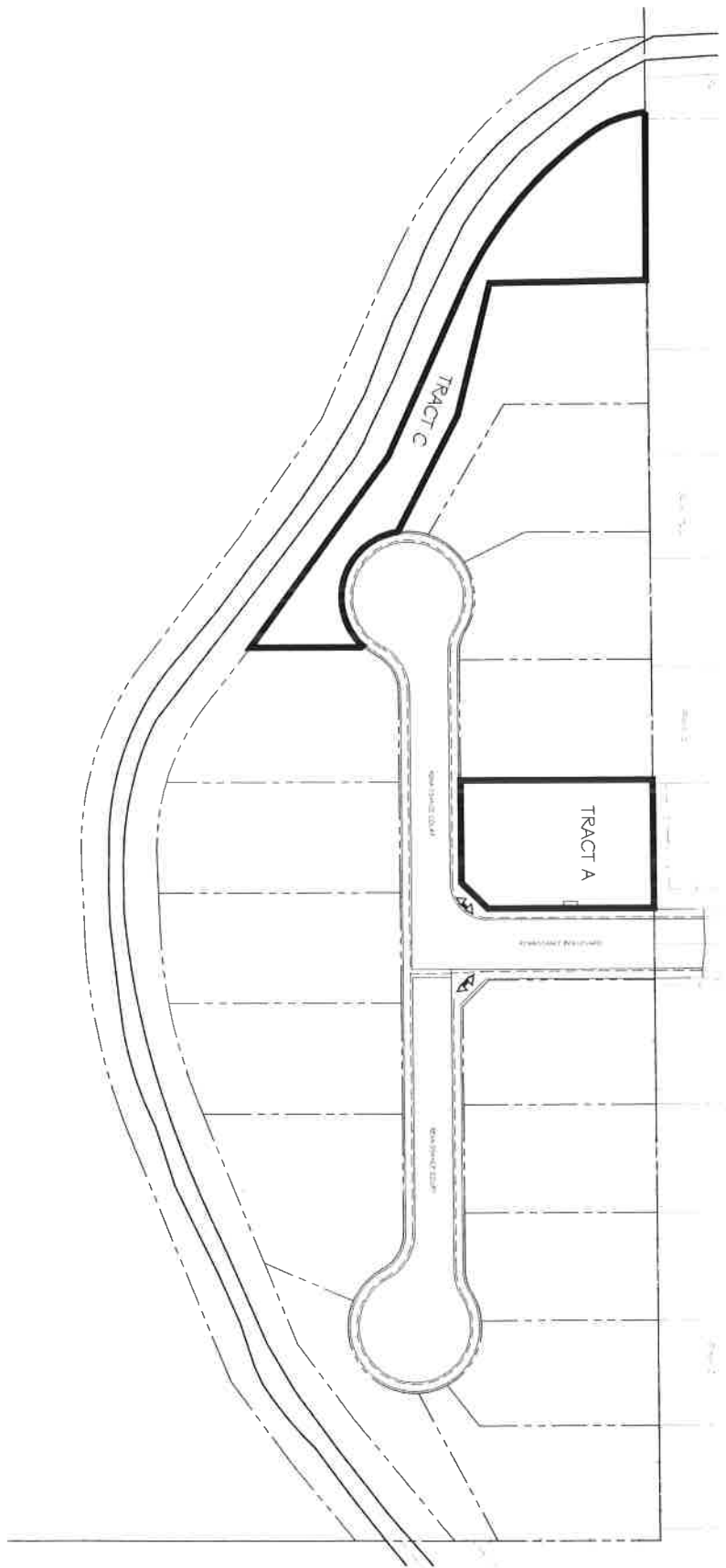
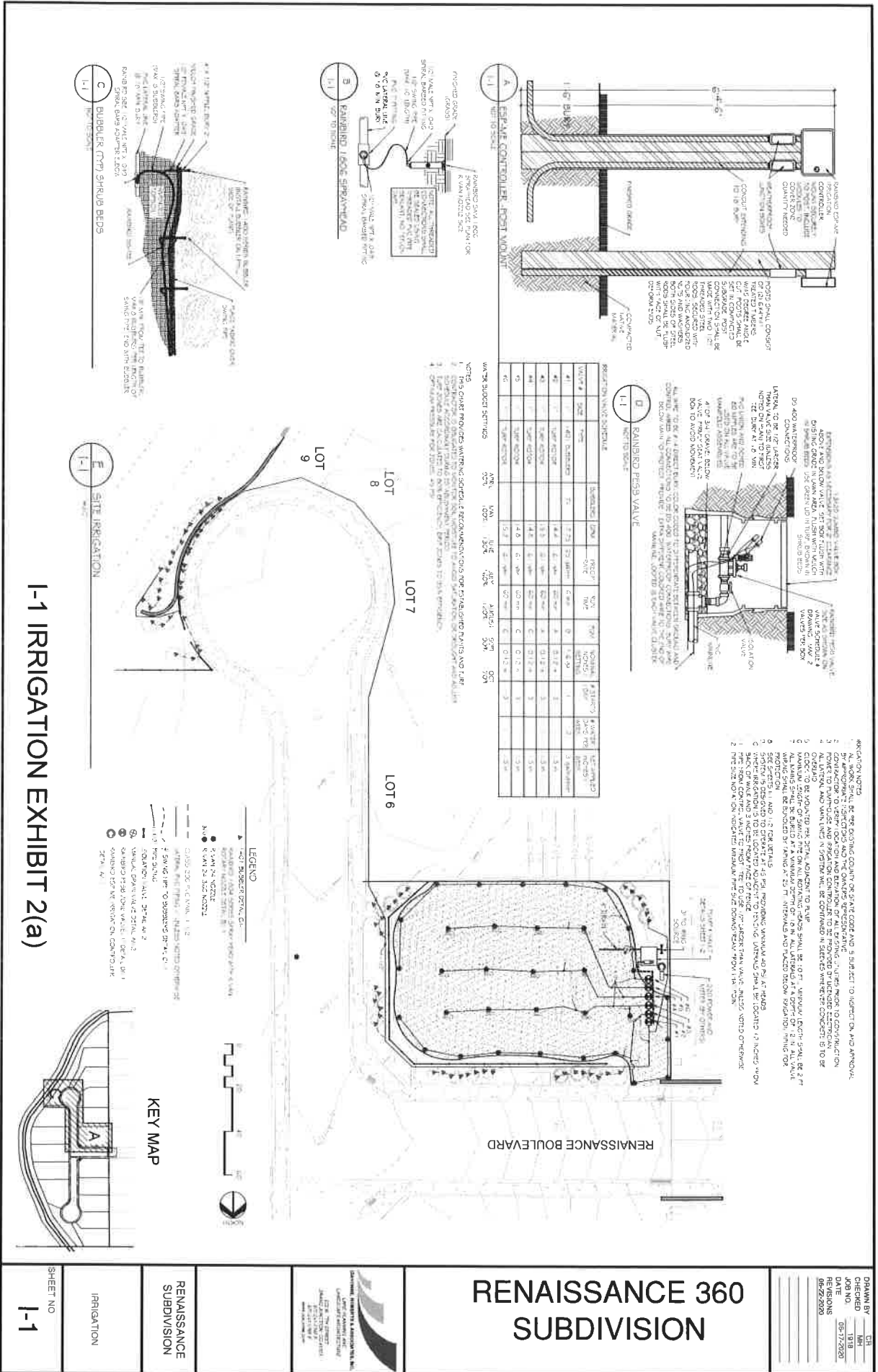

EXHIBIT 1 - RENAISSANCE IRRIGATION AGREEMENT



DRAWN BY TC CHECKED JRM DATE 05-26-2020 REVISIONS	RENAISSANCE 360 SUBDIVISION		<p> <small> RENAISSANCE 360 SUBDIVISION, LLC 15000 West 36th Avenue, Suite 100 Greenwood Village, CO 80122 (303) 750-1000 www.renaissance360.com </small> </p>	RENAISSANCE SUBDIVISION
	OVERALL LANDSCAPE PLAN			SHEET NO. E-1



RENAISSANCE 360 SUBDIVISION

DRAWN BY: MB
 CHECKED BY: MB
 DATE: 05-17-2020
 REVISIONS:
 06-25-2020

SHEET NO. I-1

RENAISSANCE
SUBDIVISION
IRRIGATION



I-1 IRRIGATION EXHIBIT 2(a)

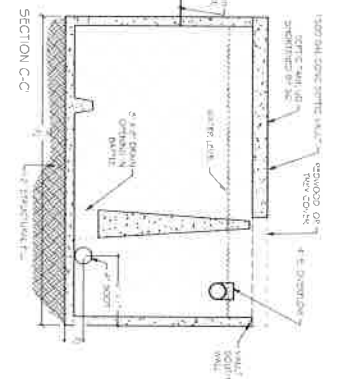
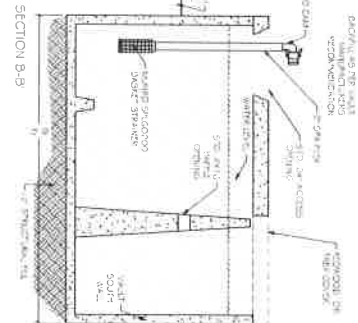
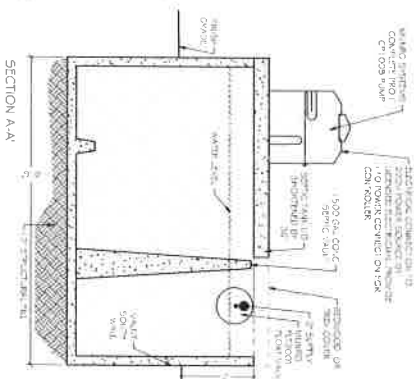
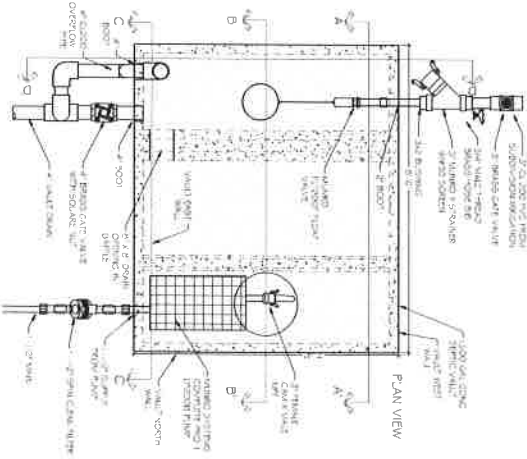
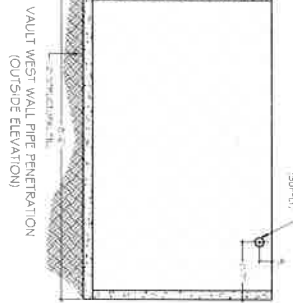
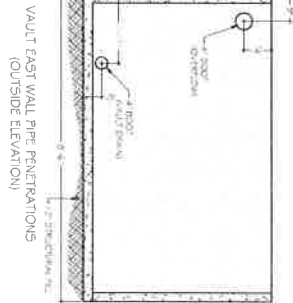
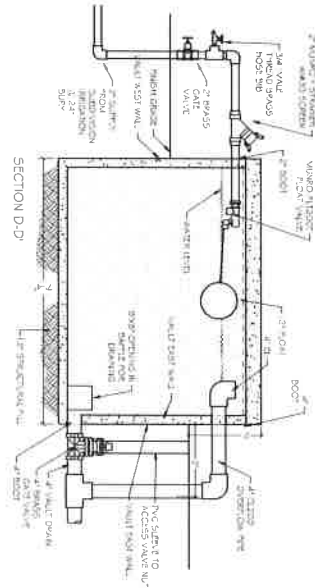

A IRRIGATION VAULT & PUMP
1-1 NOT TO SCALE

I-2 IRRIGATION EXHIBIT 2(b)

DRAWN BY: LR
 CHECKED: LR
 DATE: 05-08-2020
 REVISIONS:

RENAISSANCE 360
 SUBDIVISION



I-2

IRRIGATION

RENAISSANCE
 SUBDIVISION