

INSTRUCTION MANUAL

IMDWTR02

MODEL DWT

DEEP WELL TURBINE PUMPS

INSTALLATION, OPERATION AND MAINTENANCE INSTRUCTIONS

 **GOULDS**
WATER TECHNOLOGY
a xylem brand

Foreward

This manual provides instructions for the Installation, Operation, and Maintenance of Goulds Water Technology Deep Well Turbine (DWT) Pumps. This manual covers a standard product. For special options, supplemental instructions are available. **This manual must be read and understood before installation and start-up.**

This instruction manual covers several different pump models. Most assembly, disassembly, and inspection procedures are the same for all the pumps. However, where there are differences, these differences will be noted within the manual. The design, materials, and workmanship incorporated in the construction of the Goulds Water Technology DWT Pumps makes them capable of giving long, trouble-free service. The life and satisfactory service of any mechanical unit, however, is enhanced and extended by correct application, proper installation, periodic inspection, condition monitoring and careful maintenance. This instruction manual was prepared to assist operators in understanding the construction and the correct methods of installing, operating, and maintaining these pumps.

The information contained in this book is intended to assist operating personnel by providing information on the characteristics of the purchased equipment. It does not relieve the user of their responsibility of using accepted engineering practices in the installation, operation, and maintenance of this equipment.

Goulds Water Technology shall not be liable for physical injury, damage, or delays caused by failure to observe the instructions for installation, operation and maintenance contained in this manual.

Warranty is valid only when genuine Goulds Water Technology parts are used.

Use of the equipment on a service other than stated in the order will nullify the warranty, unless written approval is obtained in advance from Goulds Water Technology.

For information or questions not covered in this manual, contact Goulds Water Technology at (806) 743-5700.

THIS MANUAL EXPLAINS :

- Proper Installation
- Start-up Procedures
- Operation Procedures
- Routine Maintenance
- Pump Overhaul
- Trouble Shooting
- Ordering Spare or Repair Parts

Owner's Information

Pump Model Number: 7CHC 6-stage

Pump Serial Number: FR4702276

Motor Model Number: H015S2BLG-C (existing US Motors)

Motor Serial Number: Frame 254TP

Dealer: Himes Drilling Company, Inc.

Grand Junction, Colorado

Dealer Telephone: (970) 242-8893

Purchase Date: 9/11/2019

Installation Date: 9/11/2019

Table of Contents

<u>SUBJECT</u>	<u>PAGE</u>
Safety	4
Safety Instructions	4
General Precautions.....	4
General Information	4
Introduction.....	4
Receiving and Checking	4
Materials and Equipment Required	5
Storage	5
General Description	6
Installation	6
Well Conditions.....	6
Foundation / Piping	10
Installing the Bowl Assembly	11
Installing the Column	12
Installing the Discharge Head.....	13
Installing the Stuffing Box	14
Installing the Tension Plate.....	15
Installing the Driver	16
Pump Start Up and Operation	18
Preventive Maintenance	19
Packing Adjustment and Replacement.....	19
Seasonal Shutdown.....	19
Preventive Maintenance Schedule.....	20
Recommended Lubricants	20
Troubleshooting	22
Disassembly and Reassembly	24
Disassembly.....	24
Inspection and Reassemble	25
Repair Parts	26
Limited Warranty	28

Safety Instructions

TO AVOID SERIOUS OR FATAL PERSONAL INJURY OR MAJOR PROPERTY DAMAGE, READ AND FOLLOW ALL SAFETY INSTRUCTIONS IN THE MANUAL AND ON THE PUMP.



This is a **SAFETY ALERT SYMBOL**. When you see this symbol on the pump or in the manual, look for one of the following signal words and be alert to the potential for personal injury or property damage.



DANGER Warns of hazards that **WILL** cause serious personal injury, death or major property damage.



WARNING Warns of hazards that **CAN** cause serious personal injury, death or major property damage.



CAUTION Warns of hazards that **CAN** cause personal injury or property damage.

NOTICE: INDICATES SPECIAL INSTRUCTIONS WHICH ARE VERY IMPORTANT AND MUST BE FOLLOWED.

THIS MANUAL IS INTENDED TO ASSIST IN THE INSTALLATION AND OPERATION OF THIS UNIT. THOROUGHLY REVIEW ALL INSTRUCTIONS AND WARNINGS PRIOR TO PERFORMING ANY WORK ON THIS PUMP.

MAINTAIN ALL SAFETY DECALS.



Install, ground and wire according to local and National Electrical Code Requirements.



Install an all leg disconnect switch near the pump.



Disconnect and lockout electrical power before installing or servicing the pump.



Electrical supply must match motor's nameplate specifications. Incorrect voltage can cause fire, damage motor and void the warranty.



Single phase pump motors are equipped with an automatic thermal protector, which opens the motor's electrical circuit when an overload condition exists. This can cause the pump to start unexpectedly.

General Precautions



Personal injuries will result if procedures outlined in this manual are not followed



Electric supply MUST match pump's nameplate specifications. Incorrect voltage can cause fire, damage to motor and voids warranty.

Safety Apparel:

- Insulated work gloves when handling hot sand collar.
- Heavy work gloves when handling parts with sharp edges especially impellers.
- Safety glasses (with side shields) for eye protection.
- Steel-toed shoes for foot protection when handling parts, heavy tools, etc.

- Other personal protective equipment to protect against hazardous/toxic fluid.

Maintenance Safety:

- Always lock out power.
- Ensure pump is isolated from system and the pressure is relieved before disassembling the pump, removing plugs, or disconnecting the piping.
- Use proper lifting and supporting equipment to prevent serious injury.
- Observe all decontamination procedures.

General Information

INTRODUCTION

NOTE: The information in this manual intends to be used as a guide only. If you are in doubt, consult your Goulds Water Technology representative for specific information about your pump.

The design, material, and workmanship incorporated in the construction of Goulds Water Technology DWT pumps makes them capable of giving long, trouble free service. The life and satisfactory service of any mechanical unit, however, is enhanced and extended by correct application, proper installation, periodic inspection and careful maintenance. This instruction manual was prepared to assist operators in understanding the construction and the correct methods of installing, operating and maintaining these pumps.

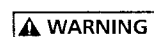

Rotating components of the pump assembly must be covered with a suitable rigid guard to prevent injury to personnel.

Study thoroughly and carefully follow the instructions for installing and operating. For questions on trouble shooting and maintenance, see the "Preventive Maintenance" Section. Keep this instruction manual handy for reference.



Goulds Water Technology will not be liable for any damages or delay caused by failure to comply with the provisions of this instruction manual.

RECEIVING AND CHECKING

The pump should be carefully supported prior to unloading from the carrier. Handle all components carefully. Inspection for damage of the shipping crate should be made prior to unpacking the pump. After unpacking, visually inspect the pump and check the following:

1. Contents of the pump assembly against the packing list.
2. All components against damage.
3. All shafting for damage, should the crate be broken or show careless handling.

Any shortages or damages should be immediately called to the attention of the local freight agent of the carrier by which the shipment arrived and proper notation made on the bill. This will prevent any controversy when claim is made and facilitate prompt and satisfactory adjustment.

MATERIALS AND EQUIPMENT REQUIRED

The material and equipment necessary for installation of the pump will vary with the size of the pump and the type of installation.

The following list of standard tools and supplies is offered only as a guide.

BULK MATERIAL

- Anti-Galling lubricant (such as Dow Corning “MOLYKOTE”)
- Thread Compound
- Lubrication Oil
- Turbine Oil
- Grease

RIGGING EQUIPMENT

- Mobile power hoist, traveling crane or derrick.
- Drag line and blocks.
- Lifting Bail for Threaded Column
- Elevator clamps, if unit is unassembled.
- Clevises – for use with eyebolts.
- Timbers – size, length, and quantity to support long pump parts on the floor.
- I-Beams or timbers to support pump over installation.

HAND TOOLS

- Pipe wrenches.
- Feeler gauges.
- Machinist level.
- Set of mechanics tools including: files, wire brush, pliers, wire cutters and pocket knife.
- Clean rags.
- Dial indicator to assist in motor and pump alignment.

OPTIONAL TOOLS TO FACILITATE PUMP ASSEMBLY AND DISASSEMBLY

- Taperlock driver to assist in bowl assembly and disassembly for pumps with taper lock impellers only.

STORAGE

Goulds Water Technology carefully preserves and protects its products for shipment. However, the effective life of the preservatives applied at the factory can vary from 3 to 18 months depending on the severity of the environment in which the equipment is stored. This section provides procedures for preparation prior to storage and maintenance during storage of Goulds Water Technology DWT pumps. These procedures are necessary to protect the precision parts of the pumps. Specific procedures for storing motors, gearheads, and engines, should be obtained from the equipment manufacturer. This section is intended to be of general assistance to users of Goulds Water Technology DWT pumps. It shall not modify, amend and/or otherwise alter the scope of Goulds Water Technology DWT pumps warranty responsibilities to the purchaser in any way whatsoever.

Storage Preparation

Goulds Water Technology DWT pumps require proper preparation for storage and regular maintenance during storage. The pump shall be considered in storage when it has been delivered to the job site and is awaiting installation.

Preferably, the storage area shall be paved, well drained and free from flooding, and be indoors whenever possible.

Weatherproof coverings used for outdoor storage shall be flame resistant type sheeting or tarpaulins. They shall be placed so as to provide good drainage and air circulation and shall be tied down to protect from wind damage.

Storage area shall be maintained in a clean condition at all times.

Pumps and/or component parts shall be placed on skids, pallets, or shoring to permit good air circulation.

Pumps and/or component parts shall be sorted so as to permit ready access for inspection and/or maintenance without excessive handling.

Pumps and/or component parts stacked during storage shall be arranged so that the racks, containers, or crates bear full weight without distortion of pumps or parts. Identification markings must be readily visible. Any cover removed for internal access shall be replaced immediately.

Pump and bowl assembly shafting shall be rotated counter clockwise, as a minimum, once a month. Shaft shall not be left in the same previous position, nor in the extreme raised or lowered lateral position. Shaft should rotate freely.

NOTE: For further information on these procedures, contact your Goulds Water Technology representative.

Recommended Storage Procedures

Controlled storage facilities should be maintained at an even temperature 10° F (6° C) or more above the dew point with relative humidity less than 50% and little or no dust. (If these requirements can not be met the pump is to be considered in uncontrolled storage.)

For uncontrolled storage periods of 6 months or less, the pump is to be inspected periodically to insure that all preservatives are intact.

All pipe threads and flanged pipe covers are to be sealed with tape.

The pump must not be stored closer than six inches (15 cm) from the ground.

Uncontrolled Long Term Storage Preparations

When applicable to the pump, storage periods over six months require the preceding storage procedure and storage preparation plus the following:

Inspect the lube oil piping and either fill the piping with rust preventative oil, or re-coat the piping periodically to prevent corrosion.

Place 10 pounds (4.5 kg) of moisture absorbing desiccant or 5 pounds (2.3 kg) of vapor phase inhibitor crystals near the center of the pump. If the pump is assembled, place an additional one pound (0.5 kg) in the discharge nozzle securely fastened to the discharge elbow.

Install a moisture indicator near the perimeter of the pump. Cover the pump with 6 mil. (0.15 mm) minimum thickness black polyethylene or equal and seal it with tape. Provide a small ventilation hole approximately ½ inch (12 mm) diameter.

Provide a roof or shed shelter to protect from direct exposure to the elements.

GENERAL DESCRIPTION

The model DWT pump is a vertical turbine lineshaft pump, which is designed to meet wide ranges of service with maximum dependability. See Figure 1 for open lineshaft pump and Figure 2 for enclosed lineshaft pump.

Drivers

Hollow shaft motors or right angle gear drives, are often used with a separate head shaft through the driver and connected to the pump by a threaded coupling.

Discharge Head

The discharge head is either a cast iron head or a fabricated Steel head. Ports are provided for connecting the pressure gauge, stuffing box bypass return and lubricator connections. The driver support portion of the discharge head is designed with large windows for easy stuffing box or tension plate adjustment. The windows are covered with coupling guards for safe operation.

Column

Threaded or flanged column construction provides positive shaft and bearing alignment. Bearings are spaced to provide vibration free operation below the shaft. This will insure long bearing life and reduced shaft wear. For open lineshaft, the shaft is supported within the column by using bearing retainers in the column assembly. For enclosed lineshaft, the bearings are also the tube couplings of the shaft-enclosing tube. The shaft-enclosing tube is stabilized in the column pipe by tube stabilizer.

Bowl Assembly

The bowls are generally of flanged construction for accurate alignment and ease of assembly and disassembly. Impellers may be either open or enclosed depending on the design requirements. They are fastened to the pump shaft by taperlocks. For temperatures over 140°F (60°C) and in the larger size bowls (over 18”), impellers are keyed to the shaft.

Installation

WELL CONDITIONS

When the DWT pump is to be installed in a well, consideration must be given to the well before installation. Check the inside diameter of the well and the maximum outside diameter of the bowl and column assemblies to determine that there is adequate clearance to install the pump assembly in the well casing. Also insure that the well is deep enough to receive the full length of pump.

1. The DWT pump unit must be operated in a straight portion of the well.

⚠ CAUTION *Installing a unit in a crooked well may bind and distort the pump column with potential resulting malfunction.*

2. When the straightness of the well is not known, the well should be “gauged” prior to installation by lowering a dummy assembly, slightly longer and larger diameter than the bowl assembly. Gauging is also important when a stepped well casing is used, with the lower part of the well casing having small inside diameter.
3. The well should be developed with a test pump prior to installing the permanent pump. Test pumping the well serves several purposes. It removes the excess sand encountered during the initial pumping of the well. Pumping sand or other abrasives with a DWT pump will shorten the life of the pump and can void the warranty.
4. The test pumping also provides a means of determining the capacity and drawdown. The well capacity should equal or exceed the pump capacity. If the pump removes water at a higher rate than the well produces, the drawdown will be excessive and the pump will cavitate or ‘starve’ resulting in damage to the pump.
5. The pump must be equipped with enough column pipe to assure that the bowl assembly remains submerged during operation.

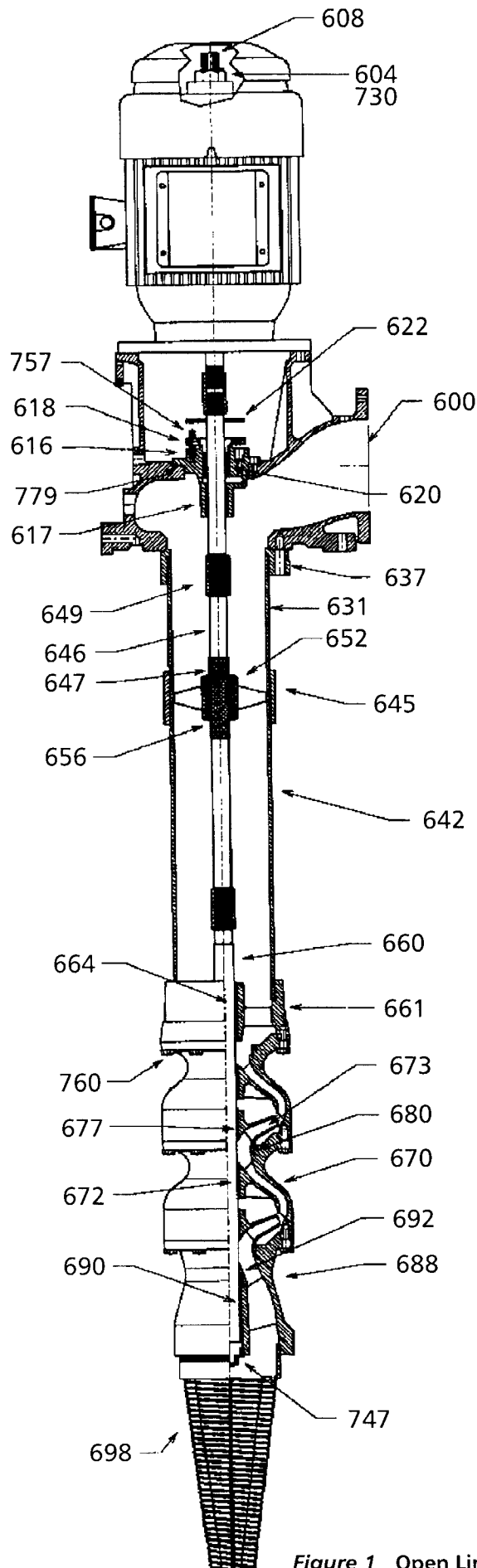

DISCHARGE HEAD ASSEMBLY

ITEM	DESCRIPTION
608	HEADSHAFT
604	ADJUSTING NUT
730	GIB KEY
622	SLINGER
600	DISCHARGE HEAD
617	STUFFING BOX BEARING
616	STUFFING BOX
779	STUFFING BOX GASKET
618	SPLIT GLAND
757	GLAND ADJUSTING NUT
620	PACKING
637	COLUMN FLANGE

COLUMN ASSEMBLY

631	COLUMN NIPPLE
645	COLUMN COUPLING
642	COULMN PIPE
646	LINESHAFT
647	LINESHAFT SLEEVE
652	BEARING RETAINER
656	LINESHAFT BEARING
649	LINESHAFT COUPLING

BOWL ASSEMBLY

660	BOWL SHAFT
661	DISCHARGE BOWL
664	DISCHARGE BEARING
670	INTERMEDIATE BOWL
672	INTER. BOWL BEARING
673	IMPELLER
677	TAPERLOCK
680	WEAR RING (OPTIONAL)
760	HEX BOLT
692	SAND COLLAR
688	SUCTION BOWL/BELL
690	SUCTION BEARING
698	SUCTION STRAINER
747	PLUG

Figure 1 Open Lineshaft Pump

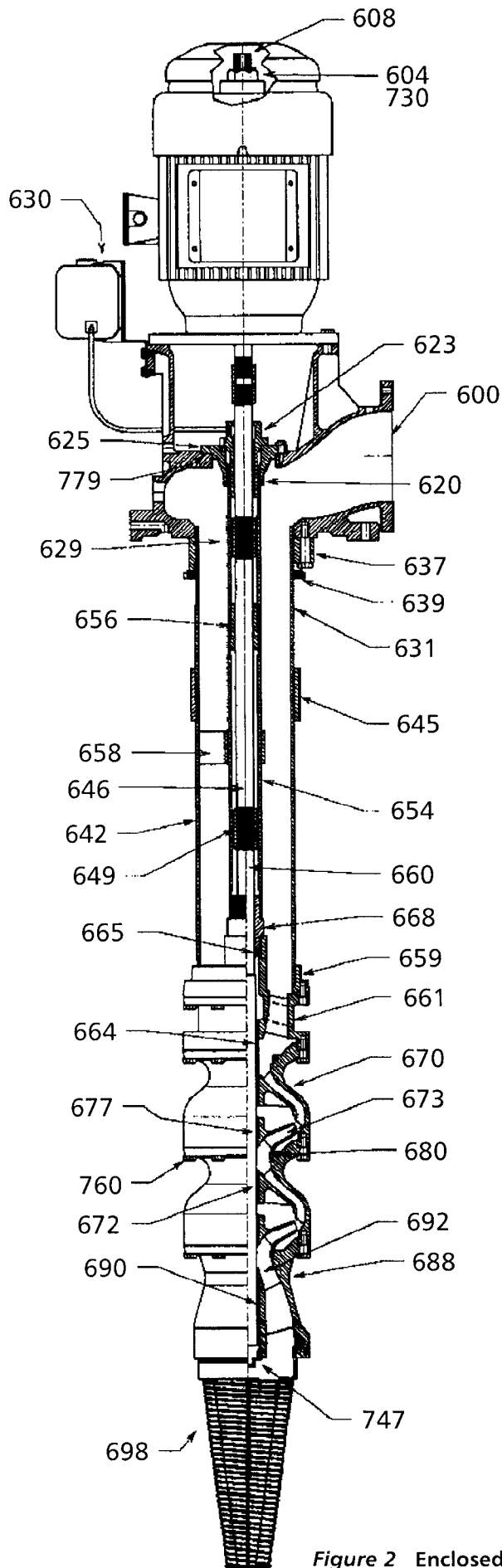

HEAD ASSEMBLY

ITEM	DESCRIPTION
608	HEADSHAFT
604	ADJUSTING NUT
730	GIB KEY
600	DISCHARGE HEAD
630	OIL RESERVOIR
623	TENSION NUT
625	TENSION PLATE
779	TENSION PLATE GASKET
620	O'RING
637	COLUMN FLANGE

COLUMN ASSEMBLY

639	COLUMN LOCK RING
631	COLUMN NIPPLE
645	COLUMN COUPLING
642	COLUMN PIPE
629	TUBE NIPPLE
654	OIL TUBE
658	TUBE STABILIZER
646	LINESHAFT
647	LINESHAFT SLEEVE
656	LINESHAFT BEARING
649	LINESHAFT COUPLING

BOWL ASSEMBLY

660	BOWL SHAFT
668	TUBE ADAPTER BEARING
665	OIL SEAL
659	COLUMN ADAPTER
661	DISCHARGE BOWL
664	DISCHARGE BEARING
670	INTERMEDIATE BOWL
672	INTER. BOWL BEARING
673	IMPELLER
677	TAPERLOCK
680	WEAR RING (OPTIONAL)
760	HEX BOLT
692	SAND COLLAR
688	SUCTION BOWL/BELL
690	SUCTION BEARING
698	SUCTION STRAINER
747	PLUG

Figure 2 Enclosed Lineshaft Pumps

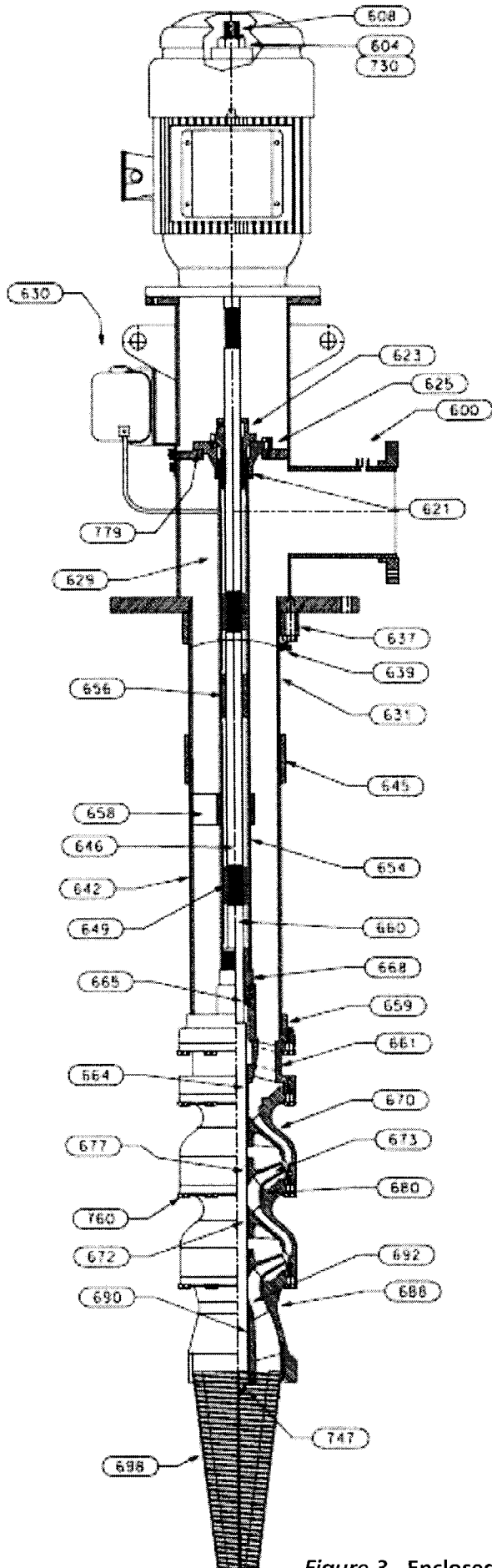

HEAD ASSEMBLY

ITEM	DESCRIPTION
608	HEADSHAFT
604	ADJUSTING NUT
730	GIB KEY
600	DISCHARGE HEAD
630	OIL RESERVOIR
623	TENSION NUT
625	TENSION PLATE
779	TENSION PLATE GASKET
620	O'RING
637	COLUMN FLANGE

COLUMN, OIL TUBE AND LINESHAFT ASSEMBLY

639	COLUMN LOCK RING
631	COLUMN NIPPLE
645	COLUMN COUPLING
642	COLUMN PIPE
629	TUBE NIPPLE
654	OIL TUBE
658	TUBE RETAINER
646	LINESHAFT
647	LINESHAFT SLEEVE
656	LINESHAFT BEARING
649	LINESHAFT COUPLING

BOWL ASSEMBLY

660	BOWL SHAFT
668	TUBE ADAPTER BEARING
665	OIL SEAL
659	COLUMN ADAPTER
661	DISCHARGE BOWL
664	DISCHARGE BEARING
670	INTERMEDIATE BOWL
672	INTER. BOWL BEARING
673	IMPELLER
677	IMPELLER, TAPERLOCK
680	WEAR RING (OPTIONAL)
760	HEX BOLT
692	SAND COLLAR
688	SUCTION BOWL/BELL
690	SUCTION BEARING
698	SUCTION STRAINER
747	PLUG

Figure 3 Enclosed Lineshaft Pumps

FOUNDATION AND PIPING

SUB BASE (SOLE PLATE) INSPECTION

Sub base and sole plate are terms in common use to describe a general class of solid steel plates mounted in grout (or bolted to steel structures) at the pump-foundation interface.

1. Remove the sub base from the pump discharge head, when shipped assembled.
2. Completely clean the underside of the sub base. It is sometimes necessary to coat the underside of the sub base with an epoxy primer. (This is available as an option.)
3. Remove the rust preventative solution from the machined topside with an appropriate solution.

SITE WITH CONCRETE FOUNDATION

1. A pump should have adequate space for operation, maintenance and inspection.
2. Sub base mounted pumps are normally grouted on a concrete foundation, which has been poured on a solid footing. The foundation must be able to absorb any vibration and to form a permanent, rigid support for the pumping unit.
3. The foundation must be of adequate strength to support the complete weight of the pump, plus the weight of the liquid passing through it. A typical installation will have bolts with a pipe sleeve $2\frac{1}{2}$ times the bolt diameter embedded in the concrete.

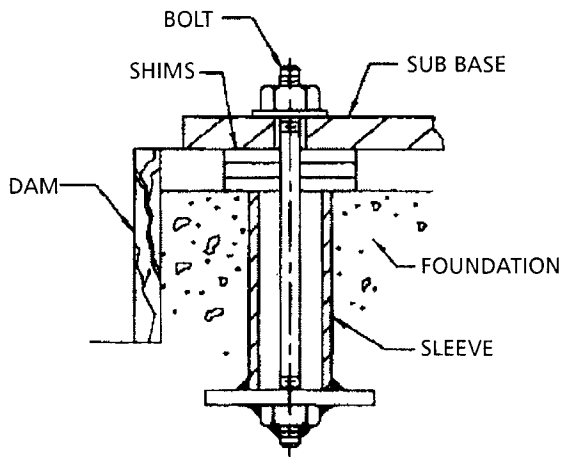

Figure 4

Bolts should be sized and located in accordance with the dimensions given on the Certified Pump Outline Drawing, if provided. The pipe sleeve allows movement for the final positioning of the foundation bolts to conform to the holes in the sub base flange. See Figure 3.

4. Remove water and/or debris from anchor bolt holes/sleeves prior to grouting. If the sleeve type bolts are being used, fill the sleeves with packing or rags to prevent grout from entering.

5. Carefully lower the sub base onto the foundation bolts. Hand tightens the nuts.
6. Leveling the sub base may be done by several methods. Two common methods are:
 - A. Using leveling the wedges. This is shown in Figure 4.
 - B. Leveling nuts on the anchor bolts.

Regardless of the method, a machinist level must be used for leveling.

NOTE: When using a machinist level, it is important that the surface being leveled is free of all contaminants, such as dust, to ensure an accurate reading.

7. Level the sub base in two directions at 90 degrees on the machined surface. The levelness tolerance is 0.005 inches per foot for commercial, and 0.001 inches per foot for API.

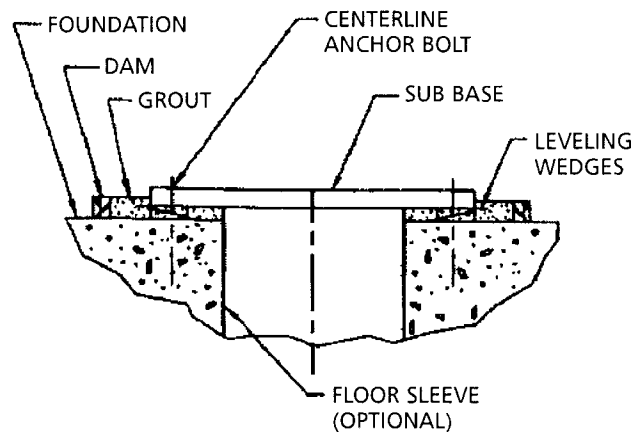

Figure 5

SUB BASE GROUTING

1. Inspect foundation for dust, dirt, oil, chips, water, etc. and remove any contaminants. Do not use oil-based cleaners as grout will not bond to it. Refer to grout manufacturer's instructions.
2. Build dam around foundation (See Figure 4). Thoroughly wet foundation.
3. Pour grout between sub base and concrete foundation, up to level of dam. Remove air bubbles from grout as it is poured by puddling, using a vibrator, or pumping the grout into place. Non-shrink grout is recommended.
4. Allow grout to set at least 48 hours.
5. Tighten foundation bolts.

PIPING

Guidelines for piping are given in the "Hydraulic Institute Standards", available from: Hydraulic Institute, 9 Sylvan Way, Parsippany, NJ 07054-3802 and must be reviewed prior to pump installation.

▲ WARNING *Never draw piping into place by forcing the flange connections of the pump. Pipe strain will adversely effect the operation of the pump resulting in damaging the equipment and possible physical injury.*

1. All piping must be supported independently and line up naturally with the pump flange so that undue pipe strain is not imposed on the pump.
2. **DO NOT** connect piping to pump until grout has hardened and pump hold-down bolts have been tightened.
3. It is suggested that expansion loops or joints, if used, be properly installed in discharge line. When handling liquids at elevated temperatures expansion joints are used, so linear expansion of piping will not draw pumps out of alignment.
4. Carefully clean all pipe parts, valves and fittings, and pump branches prior to assembly.
5. Isolation and check valves should be installed in discharge line. Locate the check valve between isolation valve and pump, this will permit inspection of the check valve. The isolation valve is required for regulation of flow, and for inspection and maintenance of pump. The check valve prevents pump or seal damage due to reverse flow through the pump when the driver is turned off.
6. Increasesers, if used, should be placed between pump and check valves.
7. Cushioning devices should be used to protect the pump from surges and water hammer if quick-closing valves are installed in the system.

INSTALLING THE BOWL ASSEMBLY

▲ WARNING *Do not work under a heavy suspended object unless there is positive support and safe guards, which will protect personnel, should a hoist or sling fail.*

▲ CAUTION *Do not attempt to lift bowl assembly by the pump shaft. This can result in damaging the pump shaft.*

1. Prior to installing the bowl assembly, check that all capscrews are tight. Turn the pump shaft by hand and make sure it turns freely. Remove all accumulated dust, oil or other foreign material from the external surfaces.
2. If pump setting exceeds 200 ft., measure the available bowl assembly lateral (shaft end play) by pushing shaft toward suction bowl, mark shaft, pull shaft out and mark again. Measure the distance between the marks and record. This will later aid in adjusting the final impeller position.

For pump setting over 200 ft. this measure must complete before proceeding.

3. Place two I-beam supports across the base plate opening, strong enough to safely support the weight of the entire pump assembly. These I-beams should be connected by threaded rods and nuts so as to clamp them firmly together for the portion to be supported. (See Figure 5).

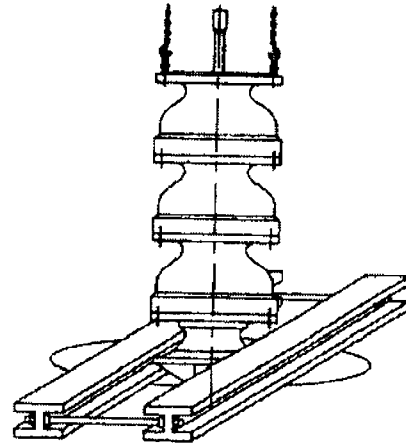

Figure 6

4. Place a suitable hoist or derrick over base plate opening with the hook in the center.
5. If a suction strainer is provided, assemble it to the suction bowl or to the end of suction pipe (if provided).
6. Install suction pipe, if provided. Place an elevator clamp just below the pipe threads. Attach a sling to the clamp and to hoist hook. Hoist over the well. Lower the suction pipe until clamp rests firmly on the supporting timbers.
7. Place the elevator clamps just below the discharge bowl. For flanged column install two threaded eyebolts through the discharge bowl bolt holes 180° apart for flanged column. For threaded discharge utilize a lifting bail sized to handle the weight of the bowl assembly and suction apparatus.
8. Attach a sling to the elevator clamps, eyebolts, or lifting bail and hoist it into position over the foundation opening. (See Figure 6).
9. If suction pipe is provided, lower the bowl assembly until the bottom end of the suction bowl meets the top end of the suction pipe. Screw the bowl assembly onto the suction pipe.
10. Carefully lower bowl assembly, guiding the unit so it does not strike the sides of the opening. Continue to lower bowl assembly until the elevator clamps or discharge bowl flange rests firmly on the I-beam supports.
11. Place a cover over the discharge bowl opening to prevent entrance of dirt or other foreign matter until ready for installation of the column assembly.

▲ CAUTION *Do not drop any foreign object into the bowl assembly. Such an object can cause serious damage to the pump and any downstream components. Any foreign object dropped into the bowl assembly must be retrieved prior to continuing assembly.*

INSTALLING THE COLUMN

OPEN LINESHAFT

Lineshafts are coupled with threaded or keyed couplings. Column pipe may be threaded or flanged. When provided, see the Certified Pump Outline Drawing for the number of column and shaft sections required. The top and bottom sections may be special lengths:

1. Check the lineshaft (646) for straightness. Average total runout should be less than 0.0005" TIR per foot, not to exceed 0.005" T.I.R. for every 10 feet of shafting.

NOTE: Bottom section of column pipe should not be longer than 5 feet.

2. Hoist the first piece of lineshaft over the bowl assembly. Lower the lineshaft until the bottom end is properly aligned with the coupling of the pump shaft. Apply a thin film of oil to the threads on the lineshaft (646) and the coupling (649) (for non-galling material or Molykote if galling material).

CAUTION Use "MOLYKOTE" Dow Corning or equal for all galling material such as 316 stainless steel.

- 3a. With lineshaft in the proper position on the coupling, screw lineshaft into the coupling manually until resistance is felt. A fine wire inserted in the hole at the center of the coupling can be used as a gage to determine when the coupling is correctly positioned on the shaft. Remove the wire after installing the shaft. Completely tighten the joint by using a pair of pipe wrenches. Use care not to damage any bearing journal areas on the shaft.
NOTE: Shaft threads are left-handed.

CAUTION Make up threaded joints manually to verify that the threads are properly engaged prior to applying a wrench. If cross-threading occurs, break the joint and repair the threads. If the threads are beyond repair, replace the damaged part.

3b.

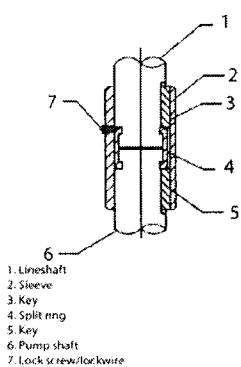

With a keyed coupling insert the key into the pump shaft. Lower the sleeve over the pump shaft, to approximately 1.0 in (25.4 mm) below the top of the shaft. Then lower the lineshaft until it touches the pump shaft. Insert the split ring into the grooves of the pump shaft and lineshaft. Raise the sleeve until it covers the split ring, then insert the key into the lineshaft. Raise the sleeve to the top of the key and secure the sleeve to the split ring with a lock screw and lock wire.

4. For threaded column, secure a friction clamp immediately below the column coupling. Hoist column section over bowl assembly. Lower column over lineshaft until column pipe engages the discharge bowl. Manually screw the column into discharge bowl. Complete joint by tightening column with chain tongs until the end of the column butts firmly against discharge bowl.
5. Lift the assembly and remove the elevator clamp or supports and slowly lower the bowl and the column assembly. Place supports on the base plate and continue to lower the assembly until the column elevator clamps or column flange comes to rest on the supports. Place an elevator clamp under the column pipe and allow it to butt firmly against the column pipe coupling.
6. Place the bearing retainer over the shaft and locate it in the column coupling recess. Make sure the end faces of the column pipe are clean.
7. Check that the shaft is approximately centered in the bearing. Move the shaft around slightly so as to center it in its bearing. Only a slight amount of force should be required. If an excessive amount of force is required, the pipe or shaft may not be butted properly or the shaft may be bent. In any case, the problem must be corrected prior to proceeding further.
8. Repeat the preceding procedures until all column sections required have been installed.
9. Install the top shaft or stub shaft and coupling. If the pump is equipped with column adjusting nipple, install it with longer threaded end upward. (See page 13 for adjustment instruction.) Screw the lock ring on to the nipple until reach to the end of the thread.

CAUTION Do not drop any foreign object into the column assembly. Such an object can cause serious damage to the pump and any downstream components. Any foreign object dropped into the column assembly must be retrieved prior to continuing assembly.

ENCLOSED LINESHAFT

1. Insert tube (654) and shaft (646) sections into column section.
2. Place an elevator clamp near top of column just below and butt firmly against column pipe coupling (645). For flanged columns, place the elevator clamp just below the flange.
3. Attach a sling to hoist hook. Attach bottom of shaft (646) to column (644), by tying a tail rope to deep-throated clamp attached to bottom of column. (See Figure 6). Tie a clove hitch or double half hitch around the enclosing tube and then around the shaft in threaded area. Figure 6 also shows the alternate method (dotted lines).
4. Utilize the remaining tail rope to keep tension on the knots during hoisting. Lower end of column section shall be guided by a drag line which is pulled by the hoist. A traveling block for the drag-line shall be attached to a deep-throated clamp, which is secured to bottom of the column threads.

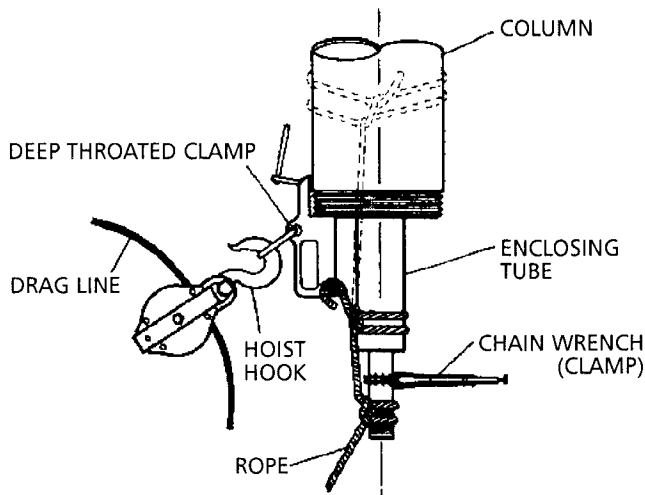

Figure 7

5. Hoist column section over pump, keeping tension on tail rope. With column in a vertical position, remove drag-line and traveling block, lower column until bottom line shaft is properly aligned with pump shaft coupling.
6. Apply a thin film of oil to the threads on the lineshaft (646) and the coupling (649) (for non-galling material or Molykote if galling material).

CAUTION Use "MOLYKOTE" Dow Corning or equal for all galling material such as 316 stainless steel.

7. With lineshaft in proper position on the coupling, remove tail rope and screw lineshaft into coupling until resistance is felt. A fine wire inserted in the hole at the center of the coupling can be used as a gage to determine when the coupling is correctly positioned on the shaft. Remove the wire after installing the shaft. Complete tightening the joint by using a pair of pipe wrenches. Use care not to damage any bearing journal areas of the shaft.
NOTE: Shaft threads are left-handed.

CAUTION Make up threaded joints manually to verify that the threads are properly engaged prior to applying a wrench. If cross-threading occurs, break the joint and repair the threads. If the threads are beyond repair, replace the damaged part.

8. Carefully lower column section until lower end of the tube section rests on the adapter bearing (668). The end faces of the tube should be clean and free of nicks. Remove tail rope, clean outside of the adapter bearing and lubricate with thread compound. Screw tube section onto adapter bushing manually, until resistance is felt. Complete tube joint by utilizing a pair of pipe wrenches or chain tongs, butting the end of tube against the upper end of the tube adapter bearing.
9. Clean column threads and lubricate with thread compound.

10. Lower column until column pipe engages in the discharge bowl. Manually thread the column into discharge bowl. Complete joint by tightening column, utilizing chain tongs until the end of the column butts firmly against discharge bowl.
11. Lift the pump assembly and remove elevator clamp secured to discharge bowl. Slowly lower assembly into well or sump until elevator clamp gently comes to rest on timbers or I-beam supports and remove the sling.
12. Remove the exposed lineshaft bearing, pour oil into the tubing and reinstall the bearing. The amount of oil to be poured is given in the following table:

Tube Size	Amount of oil per section	
	10 ft. Sections	20 ft. Sections
1¼, 1½, 2	½ Cup	1 Cup
2½, 3, 3½	1 Cup	½ Qt.
4 and larger	½ Qt.	1 Qt.

See pages 19-20 for recommended oil.

13. Repeat the preceding procedures. Throughout the column assembly, install tube stabilizer (658) over the enclosing tube (654) every 40 ft. The last one should be less than 40 ft below the discharge head. Use soapy water as lubricant when sliding the stabilizer over the tube.
14. Continue the procedure until all column sections for the proper setting have been installed, excluding the column adjusting nipple (631) and tube nipple (629), if provided.
15. Install the top shaft or stub shaft and coupling. If pump is equipped with column adjusting nipple and tube nipple, install them with longer threaded end upward. Screw the lock ring (639) on to the column nipple until the end of thread. (See page 13 for adjustment instruction.)

CAUTION Do not drop any foreign object into the column assembly. Such an object can cause serious damage to the pump and any downstream components. Any foreign object dropped into the column assembly must be retrieved prior to continuing assembly.

INSTALLING THE DISCHARGE HEAD

DWT Pumps are provided with either a cast iron or fab steel type head. Install the discharge head as follows:

1. If the stuffing box (See Figure 8) or tension nut (See Figure 9) is assembled to the head, remove it and all the attached piping.
2. For threaded column, check to be sure that the flanged column (637) is securely attached to the bottom of the discharge head. Check and tighten the capscrews (or socket head screw) gradually in diametrically opposite pairs.

- Remove coupling guard if provided. Attach a sling to the lifting lugs on the side of the discharge head through windows and hoist discharge head over the protruding top shaft (or stub shaft).

CAUTION Do not bump or scrape the shaft protruding above the column. This could result in bending or damaging the shaft.

- Orient the discharge head in the required position and lower the head. Centering the vertical hole with the top shaft protruding above the column. For threaded column, continue to lower the discharge head until the large threaded hole in the bottom of the discharge head rests squarely on top of column. Clean the threads at upper end of column assembly and lubricate with thread compound. Rotate discharge head, screw it onto the column, for short set-pump, (without the column adjusting nipple) butting the top of column tightly against the discharge head.
- If pump has a column adjusting nipple (631), for open lineshaft, screw the discharge head onto the column nipple until the end of the stub shaft is "HT" below the face the driver mounting flange of the discharge head. (See Figure 7 for detail.) For enclosed lineshaft, screw the discharge head onto the column nipple until the "F" dimension is satisfied (See Figure 7). Tighten the lock ring (639).
- For flanged column, continue to lower the discharge head until the discharge head engages the column. Install capscrews and secure discharge head to the column flange. Tighten capscrews gradually in diametrically opposite pairs. Lift pump assembly high enough to allow rotation of the supports. Realign and lower assembly. Install and tighten remaining capscrews. Repeat the rotating and the tightening procedure until all capscrews are uniformly tight.

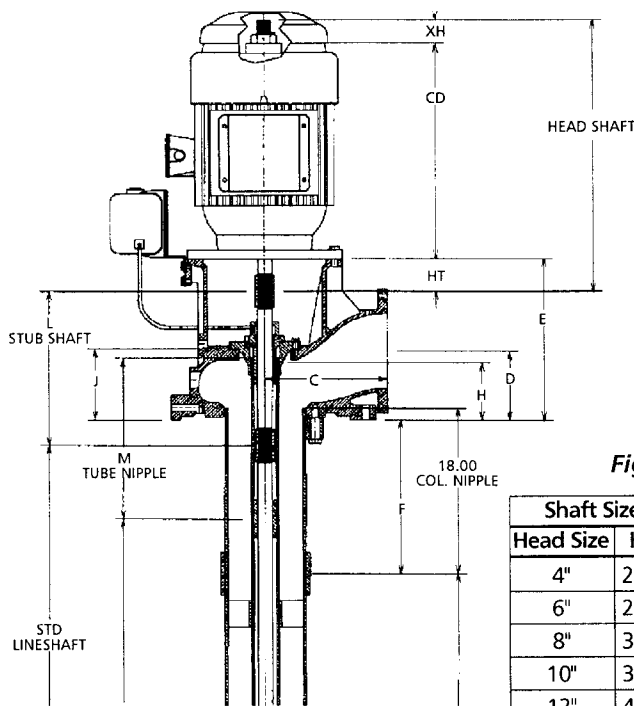

Figure 8

Shaft Size (in.)		1.00	1.19	1.50	1.69	1.94	2.18	2.44
Head Size	HT	M						
4"	2.50	17.50	H = 5.88 F = 17.62					
6"	2.88	17.50	H = 6.25 F = 17.25		H = 5.63 F = 17.88			
8"	3.00	17.50	H = 7.38 F = 16.13		H = 6.75 F = 16.75		H = 6.25 F = 17.25	
10"	3.00	17.50	H = 7.63 F = 15.88		H = 7.00 F = 16.50		H = 6.26 F = 17.00	
12"	4.69	21.00				H = 9.19 F = 17.18		H = 8.69 F = 18.31

- Hoist the discharge head by lifting lug and remove the elevator clamp attached to column.
- Remove the support timbers or I-beams and clean the top of foundation or base plate. Orient the discharge head in the required position.

NOTE: Sling should be rated to handle in excess of the pump weight.

- Lower bowl, column and head assembly, until discharge head mounting flange engages base plate. Secure discharge head to the foundation or base plate. Check the levelness of the discharge head in all directions, utilizing a machinist level across the driver's mounting surface of the discharge head.
- Check whether the top shaft (or stub shaft) is in the center of the stuffing box bore. If not, the shaft must be centered by shimming the head base and the sub base (or the foundation).
- Rotate the shaft approximately 90 degree. Check again whether the shaft is at the center of the stuffing box bore or not. If not, either the top shaft is bent or the first shaft below it did not butt properly. Correction must be made before the installation procedures can proceed.

INSTALLING THE STUFFING BOX

Assemble stuffing box as shown in Figure 8.

- Clean the surface of the discharge head where the stuffing box will be mounted and remove any nicks or burrs with a fine flat file. Position gasket on surface. Slide stuffing box (616) down over headshaft and into position on the gasket. Secure stuffing box with capscrews.
- Grease the packing ring (620) for easier installation.
- Twist the packing ring sideways to get it around the shaft easily. Start the first ring into the stuffing box. When the entire ring is worked in using the fingers, tamp it down using a split wood bushing (or equal) and push the packing ring down firmly. It must seal on the shaft and bore of the stuffing box. Install three (3) rings in this manner. Stagger ring joints 90 degrees apart. The split gland may be used as a tamper for the top ring.
- Insert lantern ring (622) into stuffing box. Be sure it is properly positioned so that it aligns with the lubrication passage in the stuffing box.
- Insert three (3) additional rings of packing. Stagger ring joints 90 degrees apart.

6. Install the split gland and screw nuts on the split gland studs. Tighten nuts then relieve the nuts and tighten finger tight. If discharge pressure is over 100 PSI, attach bypass line to the stuffing box bypass.

CAUTION Check that the split gland is square in the stuffing box. Cocking can cause uneven compression of packing and damage to the shaft or sleeve and heat up the shaft and stuffing box.

7. The stuffing box is shipped with both ports plugged. If the discharge pressure is over 100 psi, remove the plug on Port "A" and attach a bypass (relief) line. If the discharge pressure is over 200 psi, remove the plug on Port "B" and attach another bypass line.

8. Final adjustment of the stuffing box must be made at pump start up.

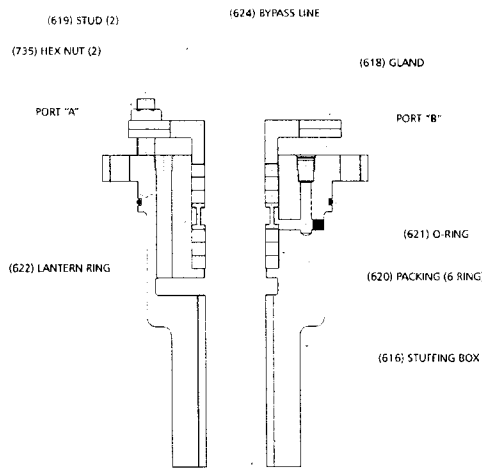

9. A properly packed stuffing box should be loose enough to allow the shaft to be turned manually.

CAUTION Do not over tighten packing or excessive wear can occur on the shaft or sleeve.

INSTALLING THE TENSION PLATE

Assemble Tension Plate Assembly as shown in Figure 9.

1. Remove the lock bolt (636) and o-ring (620). Thoroughly clean the tension plate (625) including the o-ring groove. Lightly grease the o-ring and reinstall it.

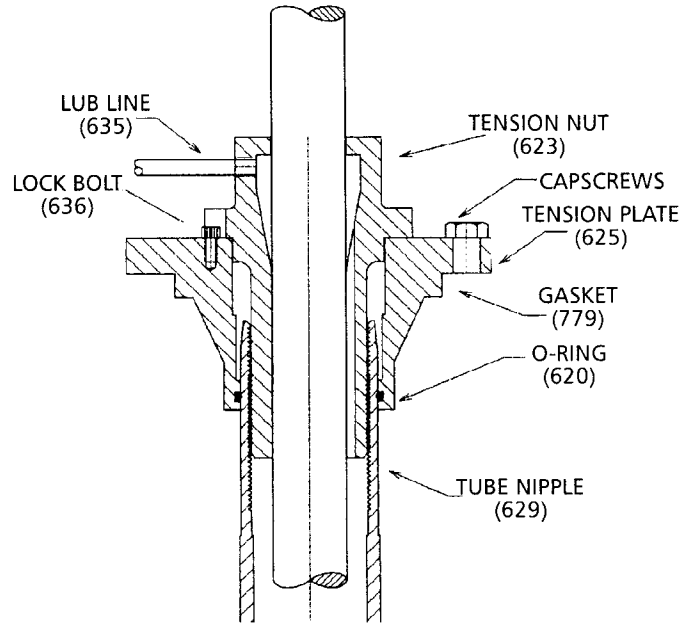

Figure 9

Figure 10

Column (Nom. Inch)	Shaft (Inch)	Tube (Nom. Inch)	Setting (Feet)															
			100			200			300			400			500			
			Tube Tension (in.)	Shaft Rise (in.)	Shaft Pull-up (in.)	Tube Tension (in.)	Shaft Rise (in.)	Shaft Pull-up (in.)	Tube Tension (in.)	Shaft Rise (in.)	Shaft Pull-up (in.)	Tube Tension (in.)	Shaft Rise (in.)	Shaft Pull-up (in.)	Tube Tension (in.)	Shaft Rise (in.)	Shaft Pull-up (in.)	
4	1	1.5	0.02	0.01	0.02	0.09	0.04	0.07	0.21	0.08	0.15	0.37	0.15	0.26	0.57	0.23	0.41	
		1.19	2	0.02	0.01	0.02	0.08	0.03	0.06	0.18	0.06	0.14	0.33	0.11	0.25	0.51	0.17	0.40
		1.5	2.5	0.03	0.01	0.02	0.11	0.06	0.07	0.25	0.13	0.16	0.45	0.23	0.28	0.71	0.36	0.44
		1.69	2.5	0.03	0.02	0.02	0.12	0.06	0.07	0.26	0.14	0.17	0.47	0.25	0.30	0.73	0.39	0.47
5	1	1.5	0.02	0.01	0.02	0.08	0.02	0.06	0.17	0.05	0.14	0.30	0.08	0.25	0.47	0.13	0.39	
		1.19	2	0.02	0.01	0.02	0.08	0.03	0.06	0.19	0.07	0.14	0.34	0.12	0.26	0.53	0.19	0.40
		1.5	2.5	0.02	0.01	0.02	0.10	0.04	0.07	0.22	0.10	0.15	0.40	0.18	0.27	0.62	0.28	0.42
		1.69	2.5	0.03	0.01	0.02	0.10	0.05	0.07	0.23	0.11	0.16	0.41	0.19	0.29	0.64	0.30	0.45
6	1	1.5	0.02	0.01	0.02	0.08	0.02	0.06	0.17	0.05	0.14	0.30	0.08	0.25	0.47	0.13	0.39	
		1.19	2	0.02	0.01	0.02	0.08	0.03	0.06	0.19	0.07	0.14	0.34	0.12	0.26	0.53	0.19	0.40
		1.5	2.5	0.02	0.01	0.02	0.10	0.04	0.07	0.22	0.10	0.15	0.40	0.18	0.27	0.62	0.28	0.42
		1.69	2.5	0.03	0.01	0.02	0.10	0.05	0.07	0.23	0.11	0.16	0.41	0.19	0.29	0.64	0.30	0.45
8	1	1.5	0.02	0.01	0.02	0.08	0.02	0.06	0.17	0.05	0.14	0.30	0.08	0.25	0.47	0.13	0.39	
		1.19	2	0.02	0.01	0.02	0.08	0.03	0.06	0.19	0.07	0.14	0.34	0.12	0.26	0.53	0.19	0.40
		1.5	2.5	0.02	0.01	0.02	0.10	0.04	0.07	0.22	0.10	0.15	0.40	0.18	0.27	0.62	0.28	0.42
		1.69	2.5	0.03	0.01	0.02	0.10	0.05	0.07	0.23	0.11	0.16	0.41	0.19	0.29	0.64	0.30	0.45
8	1.5	2	0.02	0.01	0.02	0.08	0.02	0.06	0.17	0.05	0.14	0.30	0.08	0.25	0.47	0.13	0.39	
		1.19	2	0.02	0.01	0.02	0.08	0.03	0.06	0.19	0.07	0.14	0.34	0.12	0.26	0.53	0.19	0.40
		1.5	2.5	0.02	0.01	0.02	0.10	0.04	0.07	0.22	0.10	0.15	0.40	0.18	0.27	0.62	0.28	0.42
		1.69	2.5	0.03	0.01	0.02	0.10	0.05	0.07	0.23	0.11	0.16	0.41	0.19	0.29	0.64	0.30	0.45
8	1.5	2	0.02	0.01	0.02	0.08	0.02	0.06	0.17	0.05	0.14	0.30	0.08	0.25	0.47	0.13	0.39	
		1.19	2	0.02	0.01	0.02	0.08	0.03	0.06	0.19	0.07	0.14	0.34	0.12	0.26	0.53	0.19	0.40
		1.5	2.5	0.02	0.01	0.02	0.10	0.04	0.07	0.22	0.10	0.15	0.40	0.18	0.27	0.62	0.28	0.42
		1.69	2.5	0.03	0.01	0.02	0.10	0.05	0.07	0.23	0.11	0.16	0.41	0.19	0.29	0.64	0.30	0.45
8	1.5	2	0.02	0.01	0.02	0.08	0.02	0.06	0.17	0.05	0.14	0.30	0.08	0.25	0.47	0.13	0.39	
		1.19	2	0.02	0.01	0.02	0.08	0.03	0.06	0.19	0.07	0.14	0.34	0.12	0.26	0.53	0.19	0.40
		1.5	2.5	0.02	0.01	0.02	0.10	0.04	0.07	0.22	0.10	0.15	0.40	0.18	0.27	0.62	0.28	0.42
		1.69	2.5	0.03	0.01	0.02	0.10	0.05	0.07	0.23	0.11	0.16	0.41	0.19	0.29	0.64	0.30	0.45
8	1.5	2	0.02	0.01	0.02	0.08	0.02	0.06	0.17	0.05	0.14	0.30	0.08	0.25	0.47	0.13	0.39	
		1.19	2	0.02	0.01	0.02	0.08	0.03	0.06	0.19	0.07	0.14	0.34	0.12	0.26	0.53	0.19	0.40
		1.5	2.5	0.02	0.01	0.02	0.10	0.04	0.07	0.22	0.10	0.15	0.40	0.18	0.27	0.62	0.28	0.42
		1.69	2.5	0.03	0.01	0.02	0.10	0.05	0.07	0.23	0.11	0.16	0.41	0.19	0.29	0.64	0.30	0.45
8	1.5	2	0.02	0.01	0.02	0.08	0.02	0.06	0.17	0.05	0.14	0.30	0.08	0.25	0.47	0.13	0.39	
		1.19	2	0.02	0.01	0.02	0.08	0.03	0.06	0.19	0.07	0.14	0.34	0.12	0.26	0.53	0.19	0.40
		1.5	2.5	0.02	0.01	0.02	0.10	0.04	0.07	0.22	0.10	0.15	0.40	0.18	0.27	0.62	0.28	0.42
		1.69	2.5	0.03	0.01	0.02	0.10	0.05	0.07	0.23	0.11	0.16	0.41	0.19	0.29	0.64	0.30	0.45
8	1.5	2	0.02	0.01	0.02	0.08	0.02	0.06	0.17	0.05	0.14	0.30	0.08	0.25	0.47	0.13	0.39	
		1.19	2	0.02	0.01	0.02	0.08	0.03	0.06	0.19	0.07	0.14	0.34	0.12	0.26	0.53	0.19	0.40
		1.5	2.5	0.02	0.01	0.02	0.10	0.04	0.07	0.22	0.10	0.15	0.40	0.18	0.27	0.62	0.28	0.42
		1.69	2.5	0.03	0.01	0.02	0.10	0.05	0.07	0.23	0.11	0.16	0.41	0.19	0.29	0.64	0.30	0.45
8	1.5	2	0.02	0.01	0.02	0.08	0.02	0.06	0.17	0.05	0.14	0.30	0.08	0.25	0.47	0.13	0.39	
		1.19	2	0.02	0.01	0.02	0.08	0.03	0.06	0.19	0.07	0.14	0.34	0.12	0.26	0.53	0.19	0.40
		1.5	2.5	0.02	0.01	0.02	0.10	0.04	0.07	0.22	0.10	0.15	0.40	0.18	0.27	0.62	0.28	0.42
		1.69	2.5	0.03	0.01	0.02	0.10	0.05	0.07	0.23	0.11	0.16	0.41	0.19	0.29	0.64	0.30	0.45
8	1.5	2	0.02	0.01	0.02	0.08	0.02	0.06	0.17	0.05	0.14	0.30	0.08	0.25	0.47	0.13	0.39	
		1.19	2	0.02	0.01	0.02	0.08	0.03	0.06	0.19	0.07	0.14	0.34	0.12	0.26	0.53	0.19	0.40
		1.5	2.5	0.02	0.01	0.02	0.10	0.04	0.07	0.22	0.10	0.15	0.40	0.18	0.27	0.62	0.28	0.42
		1.69	2.5	0.03	0.01	0.02	0.10	0.05	0.07	0.23	0.11	0.16	0.41	0.19	0.29	0.64	0.30	0.45
8	1.5	2	0.02	0.01	0.02	0.08	0.02	0.06	0.17	0.05	0.14	0.30	0.08	0.25	0.47	0.13	0.39	
		1.19	2	0.02	0.01	0.02	0.08	0.03	0.06	0.19	0.07	0.14	0.34	0.12	0.26	0.53	0.19	0.40
		1.5	2.5	0.02	0.01	0.02	0.10	0.04	0.07	0.22	0.10	0.15	0.40	0.18	0.27	0.62	0.28	0.42
		1.69	2.5	0.03	0.01	0.02	0.10	0.05	0.07	0.23	0.11	0.16	0.41	0.19	0.29	0.64	0.30	0.45
8	1.5	2	0.02	0.01	0.02	0.08	0.02	0.06	0.17	0.05	0.14	0.30	0.08	0.25	0.47	0.13	0.39	
		1.19	2	0.02	0.01	0.02	0.08	0.03	0.06	0.19	0.07	0.14	0.34	0.12	0.26	0.53	0.19	0.40
		1.5	2.5	0.02	0.01	0.02	0.10	0.04	0.07	0.22	0.10	0.15	0.40	0.18	0.27	0.62	0.28	0.42
		1.69	2.5	0.03	0.01	0.02	0.10	0.05	0.07	0.23	0.11	0.16	0.41	0.19	0.29	0.64	0.30	0.45
8	1.5	2	0.02	0.01	0.02	0.08	0.02	0.06	0.17	0.05	0.14	0.30	0.08	0.25	0.47	0.13	0.39	
		1.19	2	0.02	0.01	0.02	0.08	0.03	0.06	0.19	0.07	0.14	0.34	0.12	0.26	0.53	0.19	0.40
		1.5	2.5	0.02	0.01	0.02	0.10	0.04	0.07	0.22	0.10	0.15	0.40	0.18	0.27	0.62	0.28	0.42
		1.69	2.5	0.03	0.01	0.02	0.10	0.05	0.07	0.23	0.11	0.16	0.41	0.19	0.29	0.64	0.30	0.45
8	1.5	2	0.02	0.01	0.02	0.08	0.02	0.06	0.17	0.05	0.14	0.30	0.08	0.25	0.47	0.13	0.39	
		1.19	2	0.02	0.01	0.02	0.08	0.03	0.06	0.19	0.07	0.14	0.34	0.1				

2. Clean the surface of the discharge head where the tension plate will be mounted and remove any nicks or burrs with a fine flat file. Clean the O.D. of the tube nipple. Carefully install the tension plate and gasket (779). Evenly tighten the mounting capscrews (759F).
3. Pour one pint of recommended oil down the tube nipple (629). (See pages 19 and 20 for recommended lubricants.) **NOTE: Factory assembled unit has no oil in it. Oil must be added in the field.**
4. Clean the tension nut (623) and lightly oil its bore and the threads. Screw the tension nut into the tube nipple until the flange face of the nut contacts the tension plate.
5. Tighten the tension nut per the chart on page 14 to the proper amount of tube tension. Back off the tension nut until a slot aligns with the locking bolt (636). Install the locking bolt.

For setting less than 100 ft., tighten to the nearest locking position. Check the "HT" dimension (See Figure 7), be sure it is correct.
6. Connect the lubrication line (635) to the tension nut. Fill the container with the recommended oil. Check the lubricator feed and see that the oil is flowing freely.

INSTALLING THE DRIVER

INSTALLATION OF A HOLLOW SHAFT DRIVER

This refers to either VHS type electric motors or hollow shaft type gear drives. A small paragraph will be devoted to combination electric motor and right angle gear drives.

▲ WARNING *Do not work under a heavy suspended object unless there is a positive support and safe guards which will protect personnel should a hoist or sling fail.*

1. The driving mechanism of all hollow shaft driver is shown on Figure 10. The driveshaft (608) extends up through the quill or hollow shaft of the driver and is held in place by an adjusting nut (604), which not only carries all the static and hydraulic thrust of the impellers and shaft but also provides the adjustment for the impeller clearances. The head shaft is connected to top shaft (or stub shaft) by a threaded coupling or a rigid flange coupling.
2. Motor stand. When a motor stand is furnished and not installed, proceed as follows:
 - A. Hoist the motor stand, inspect the mounting surfaces, register, and clean these surfaces thoroughly.
 - B. Install the motor stand on discharge head and secure with capscrews provided.
3. Attach a sling to the lifting lugs of driver and hoist the driver up. Inspect the mounting surface, register and clean these surfaces thoroughly. If any burrs are found, remove burrs with a smooth mill file, cleaning thoroughly afterward.
4. For motor, orient the motor conduit box in the required position. For the right angle gear, orient the input shaft to the desired position. Align the driver mounting holes with the mating tapped holes on the discharge head. Lower the driver until the registers engage and the driver rests on the discharge head. Secure driver with capscrews provided.
5. Lubricate the driver bearings in accordance with instructions given on lubrication plate attached to the driver case (or in the Motor IOM).
6. After lowering and orienting the driver as explained above, remove the drive coupling and the hold down bolts (See Figure 10). **Be sure to mark the location of the coupling before remove it.**
7. Lower the head shaft through the motor quill shaft to meet the shaft coupling. Apply a thin film of oil to head shaft threads (if non-galling material) and screw into the shaft coupling (located above the stuffing box). Make sure the shaft is not damaged in any way. Tighten the joint.
8. Check that the head shaft centers inside the driver quill shaft within 0.06" (1.5 mm). If it does not, misalignment is indicated.
9. Any head shaft misalignment with driver quill shaft could be caused by a bent driveshaft, burrs, or foreign matter between shaft ends or any of the mounting flanges: motor flange to discharge head top flange, discharge head base flange to base plate or the base plate itself could be out of level. If the latter, shimming between it and discharge head base, will correct it. Also, check concentricity of motor to motor-stand (if provided) to discharge head.
10. With the motor in place and the head shaft projecting through the motor quill shaft, make temporary electrical connection to check the motor rotation. **(Be sure to remove the ratchet pins (or balls) before checking motor rotation.)** Motor must rotate counterclockwise when viewed from the top. See arrow on pump name plate. If motor does not rotate counterclockwise, you can change the rotation by interchanging any two leads. (For three phase only. For single phase motors see motor manufacturer's instructions.)

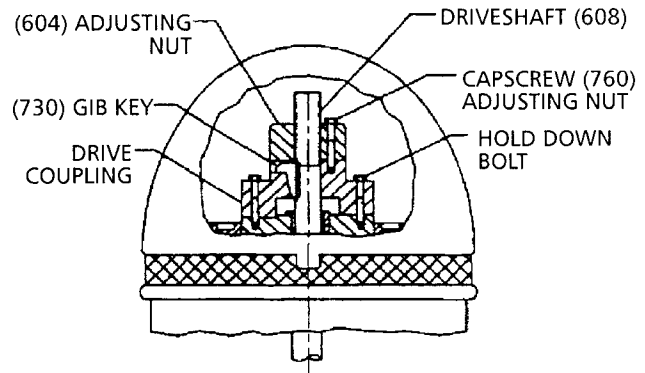

Figure 11

CAUTION Never check motor rotation with the drive coupling in place. The bore clearance between the drive coupling and the pump shaft O.D. is so close that should the motor spin with this shaft stationary, galling and locking together is very likely to take place.

11. Install motor drive coupling. (Be sure to line up the match mark made at step 6.) Inserting the ratchet pins if a non-reverse ratchet is used. Match the coupling lugs with corresponding holes in motor. Tighten hold down bolts evenly, making sure driver coupling is properly seated in the register fit.
12. Fit gib key (730) into keyway, by filing if necessary, to where there is a snug but sliding fit. This key must be able to be removed by gentle leverage with a screwdriver under it.
13. Be careful that the gib key (730) is not too high so as to hold up the adjusting nut (604) from seating on the drive coupling. If it is, cut off some length of the key.
14. Install adjusting nut (604) to hand tight.

COMBINATION ENGINE AND MOTOR DRIVES

1. On combination drivers, the motor is invariably on top with a projecting head shaft extension.
2. Follow all procedures outlined on page 15, except that the motor must be lowered over this extended head shaft and great care must be taken to center it exactly so as not to bump or miss-align the shaft while the motor is being lowered into place.
3. There are several methods of running engines without electric motors and vice versa, requiring simple adjustment to the combination drive, but they are too numerous to mention here and can be obtained from the gear manufacturers instructions included with the shipment.

IMPELLER ADJUSTMENT FOR ALL HOLLOW SHAFT DRIVES

NOTE: Shaft adjustment up or down is accomplished by turning the adjusting nut (604) Figure 10.

NOTE: There are five holes in the adjusting nut and only four in the motor coupling. See Figures 11.

1. With shafting all the way down and the impellers resting on their seats, turn the adjusting nut (604) in counterclockwise direction, thus lifting the shaft, until the impellers just clear their seats and the shaft/motor turns free by hand. This removes all deflection from the shaft. (This is the "Shaft Pull-up" in the Chart on page 14.)
2. For enclosed impellers, if pump setting is 200 ft. or less, make another two turns on the adjusting nut for the first 100 ft. (3 turns for 12 thread/inch shaft) and one additional turn for each additional 50 ft. Line-up one of the holes in the adjusting nut with the nearest hole in the driver coupling. Insert the capscrew in the hole and tighten it.

NOTE: 1.00" and 1.18" diameter shafts are 12 thread per inch (tpi), 1.50" through 2.44" are 10 tpi, all larger sizes are 8 tpi.

For pump setting over 200 ft., continue to turn the adjusting nut until impellers reach the top of bowls (resistance is felt when impellers rub against the top of bowls.) The number of turns to reach the top of the bowl should equal the total lateral obtained during bowl assembly installation as recommended in Paragraph 2 on page 10. If the lateral measured at the adjusting nut is less than that recorded previously, check the headshaft to make sure that the adjusting nut has not run out of threads and that the keyway is long enough. Also, check the shaft coupling or water slinger to make sure that neither one is being pulled up against the bottom of the driver base. Now, lower the impellers (turn the adjusting nut clockwise) by 30% of the total lateral. Line-up one of the holes in the adjusting nut with the nearest hole in the driver coupling. Insert the capscrew in the hole and tighten it.

For pump setting over 500 ft., consult factory for special instruction.

3. For Open Impellers, Align hole "A" in the adjusting nut (604) and hole "C" in the driver coupling (See Figure 11) or whatever similar holes are in like position. If care is exercised, this will give an initial impeller clearance of 0.001" to 0.003" depending on shaft size or the pitch of the thread.
4. Insert capscrew into hole "B" provided these are the nearest matching holes for counterclockwise rotation of adjusting nut, turn adjusting nut counterclockwise until holes "B" and "D" line up. This gives 1/20 of a turn which is 0.004" on 12 tpi or 0.005" on 10 tpi shaft.

5. Normal impeller clearance for the open impeller is considered to be 0.015" for the first 10 ft. of the column length and 0.010" additional clearance for each 10 ft. of length thereafter. This can be reduced in some instances where is necessary, but should not be attempted without consulting the factory or a factory serviceman if present.

(604) ADJUSTING NUT

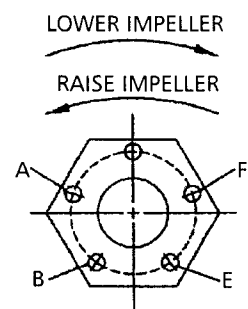

MOTOR COUPLING

ROTATION

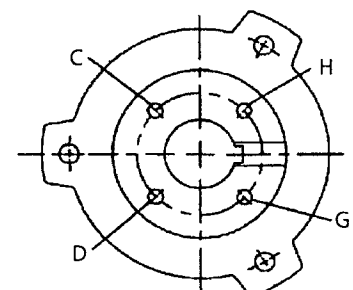

Figure 12

Pump Startup And Operation

PRE-START PROCEDURE

Consult the applicable manufacturer's instructions for detailed information for the prime mover (electric motor, engine or steam turbine), coupling, driveshaft, gear driver. Prior to startup, check the following.

1. Confirm that the following procedures described in the "Installing the Drivers" sections have been performed:

- A. Wiring of Driver.
- B. Driver must rotate counterclockwise (CCW) when viewed from above.

▲ WARNING *Do not check motor rotation unless motor is bolted to pump and drive coupling is removed.*

▲ WARNING *Be sure to install the coupling guards around all exposed shafts and couplings before start up of the pump. Failure to comply may result in sever personnel injury or death.*

- C. Check alignment of pump and driver.
- D. Impeller adjustment has been made.

2. For open lineshaft pump, make sure the stuffing box bleed line is connected (if applicable). For enclosed lineshaft pump, make sure the oil lubrication piping is connected and oil reservoir filled with the recommended oil. (See pages 19 and 20.)
3. For open lineshaft pump, when a static water level exceeds 30 feet (9 meters), pre-lubrication is necessary. If it is equipped with a prelube system supplied from a pressurized header, open the supply valve and allow the prelube water to flow for 15 seconds plus 15 seconds per 100 feet (30 meters) of pump setting. If it is equipped with a tank type prelube system, open the valve between the prelube tank and the pump and allow approximately half of the water in the tank to run into the pump before starting the pump. The pre-lube valve should remain open during the start up.

Column Size (Nom. in.)	Required Tank Capacity (Gallons)	Pre-Lub Pipe & Valve Size
3, 4	10 gal. Per 100 ft. depth to static water level	1"
5, 6	25 gal. Per 100 ft. depth to static water level	1½"
8, 10, 12, 14	50 gal. Per 100 ft. depth to static water level	1½"

4. For oil lubricated pump, clean and fill the lubricator tank with recommended oil. (See pages 19 and 20.) Manually open the lubricator valve and allow oil to run into the shaft enclosing tube for at least 20 minutes for each 100 feet (30 meters) of setting prior to start up. Then, adjust the lubricator for the proper drops per minutes according to the following table:

Shaft Size (in.)	Basic drops per minute	Additional drops per minute per 100 ft. setting
0.75 - 1.18	5	2
1.50 - 1.68	7	3
1.94 - 2.43	10	4
2.68 and larger	12	5

On the system equipped with a solenoid operated lubricator valve that cannot be energized independently, it will be necessary to remove the valve stem to allow the oil to flow into the tube. If the start up is delayed or the pump has been shut down for over 150 hours, the lubrication procedure must be repeated just prior to actual start up.

5. Open the air release system isolation valve. Adjusting the air release system throttling device so that is partially open, It should not be closed or fully open.

NOTE: Not exhausting the air or exhausting it too fast can damage the pump.

6. All connections to driver and starting device must match wiring diagram. Voltage, phase and frequency on motor nameplate must agree with line current.
7. Rotate shaft manually to ensure impellers are not binding.
8. Verify that driver bearings are properly lubricated and check oil level in housing.
9. Inspect discharge piping connection, valves and pressure gauges for proper operation.

PUMP STARTUP

1. Partially close the valve in the discharge line.
2. Start the pump. If any abnormal noises, jerking or vibration is noted, stop the pump immediately, determine the cause of the abnormalities and correct them.
3. After the pump is operating at full speed, slowly open discharge valve. If driver overheats or there is excessive vibration, stop the pump, determine the causes and correct them.
4. If the air release valve is manually operated, close it.

- For open lineshaft pumps, with the pump in operation, there should be some leakage at the stuffing box packing. The correct leakage rate is approximately one drop per second. Check the temperature of the leakage as well as the discharge head. If the pump runs hot and the leakage begins to choke off, stop the pump and allow it to cool down. A few light taps with a hammer on the gland will upset the packing sufficiently to resume leakage. After pump has cooled, restart pump and follow preceding procedure. Run pump 15 minutes, check leakage, if it exceeds two drops per second, adjust packing as described in "Packing Adjustment and Replacement".
- For enclosed line shaft pumps, adjust the lubricator valve for the proper flow rate of the lubrication oil. (See Page 17.)

Preventive Maintenance

Preventive maintenance includes periodic inspection of oil level in the oil reservoir (for pump with oil lub column), re-lubrication of electric motors, gear drives and prime mover. Systematic inspection of the pump and its components shall be made at regular intervals. The frequency required depends upon the operating conditions of the pump and its environment. See Page 19 for Preventive Maintenance Procedures. Consult the applicable manufacturer's instructions for detailed information on maintenance for the prime mover, driveshaft, electric motors and gear drives. Any deviation in performance or operations from what is expected can be traced to some specific cause. Variances from initial performance will indicate changing system conditions, wear or impending breakdown of the unit.

⚠ DANGER *Before initiating maintenance procedures, disconnect all power sources to the equipment and accessories completely. Discharge all parts and accessories which retain electric charge. Failure to comply may result in severe personnel injury or death.*

PACKING ADJUSTMENT AND REPLACEMENT

Pumps equipped with packing, shall be adjusted whenever the leakage rate exceeds two drops per second. If there is no leakage or the stuffing box overheats, do not back off gland nuts while the pump is running. This will allow the entire set of rings to move away from the bottom of the box, without relieving pressure of the packing on the shaft. Stop the pump and allow packing to cool then restart the pump.

⚠ WARNING *Be sure to reinstall the coupling guard before restarting the pump.*

It may be necessary to repeat this procedure several times before proper amount of liquid comes through to efficiently prevent overheating. If leakage is excessive, adjust the stuffing box as follows:

- With the pump in operation, tighten the gland nuts one-quarter turn for each adjustment. Allow packing to equalize against the increased pressure and leakage to gradually decrease to a steady rate, before making another adjustment.

- With the pump shut down and when packing has been compressed to the point that the gland is about to contact the upper face of stuffing box, remove the split gland, add one extra packing ring and readjust. If this fails to reduce leakage to two drops per second, remove all packing rings and replace with new rings.

⚠ CAUTION *Do not over tighten the stuffing box. Excessive pressure can wear out packing prematurely and seriously damage the shaft.*

- Remove the packing with the aid of a packing hook. If a lantern ring is provided, remove it by inserting a wire hook in the slots of the ring and pull it from the packing box. Thoroughly clean the stuffing box of all foreign matter.
- If the replacement packing is in the form of a continuous coil or rope, it must be cut into rings before installing. Tightly wrap one end of the packing material around the top shaft like one coil spring, and cut through the coil with a sharp knife. For repacking sequence, refer to "Stuffing Box Installation" (page 13).

SEASONAL SHUTDOWN

⚠ WARNING *Manually rotate shaft several times prior to restarting pump, which has been down.*

- For oil lubricated pumps that are shut down for an extended period of time, it is suggested that the pump be operated for at least 15 minutes every two weeks with oil feed wide open 2 hours before and during startup in order to maintain a film of oil on the shafting and shaft bearings.
- For product (or water) lubricated pump, if the pump is to be shut down for an extended period of time, operate it for at least 15 minutes with adequate pre-lubrication every two weeks.
- Before resuming normal operations, oil should be changed on drivers, right angle gear and lubricating oil system. After 15 minutes of operation adjust lateral.

PREVENTIVE MAINTENANCE SCHEDULE	
PROCEDURE	TIME INTERVAL (in operating hours)
Clean dirt, oil and grease from driver and discharge head.	As required.
Clean driver ventilation passage to prevent overheating.	As required.
Change lubrication in gear drive.	2,000 or once a year
Check oil level in the reservoir. It should never be less than ¼ full. Refill, check drip rate.	24
Tighten all loose bolts, and check for excessive vibration.	As required.
If packing is grease lubricated, add as required.	100
Check that there is some leakage through stuffing box while pump is in operation. Do not tighten gland nuts unless necessary. Refer to page 18 for tightening requirement.	As required
Maintain a liquid film of lubrication between the seal rubbing faces.	As required.
Re-grease the motor bearings: 1800 RPM and above Below 1800 RPM	Refer to Motor IOM Refer to Motor IOM

RECOMMENDED LUBRICANTS		
	Grease for Lineshafts, Suction Bowl Bearings and Shaft Packings	Turbine oils for Lineshafts, Suction Bowl Bearings and similar applications
Operating Temperature Range	20° F to 120° F	20° F to 120° F
Required properties Pour Point : Flash Point : 100° F Viscosity : ASTM Dropping Point : Nitrile Rubber Swell : Thickener Type: Thickener Percent:	20° F or lower (base oil) 300° F or higher (base oil) 450 SUS or higher (base oil) 160° F or higher Minimal (up to 3%) Calcium or Lithium 15% Minimum	20° F or lower 300° F or higher 150 SUS or higher 32 Minimal (up to 3%)

Manufacturer	Recommended Standard Industrial Lubricants	
Chevron Texaco Corp.	Chevron Ulti-Plex Grease EP2	Chevron *Hydraulic Oil AW32
	Texaco Novatex EP2	Texaco *Regal EP 32
CITGO Petroleum Corp.	Mystik Oil & Grease Mystik JT-6 Grease (5484)	Mystik Oil & Grease *Mystik Turbax Oil 32 (1812)
	Citgo Oil & Grease Premium Lithium EP2	Citgo Oil & Grease Pacemaker Oil 32
	Lyondell Lubricants Litholine HEP Grease	Lyondell Lubricants *Duro Oil 32
Exxon Mobil Corp.	Mobil Mobilux Grease EP2	Mobil DTE Oil 24
	Exxon Lodok EP 2	Exxon *Nuto H Hydraulic Oil 32
76 Lubricants Co.	76 Lubricants Multiplex EP Grease 2	76 Lubricants Hydraulic Oil AW/D 32
Shell Oil	Shell Alvania EP Grease 2	Shell *Tellus Plus Oil 32

*Note: In front of the oil grade means it is suitable for sub zero (F) temperature service.

Manufacturer	Recommended Food Machinery Lubricants	
Chevron Texaco Corp.	Chevron #FM Grease EP2	Chevron *#Lubricating Oil FM32
	Texaco #Cygnus Grease 2	Texaco #Cygnus Hydraulic Oil 32
CITGO Petroleum Corp.	Mystik Oil & Grease #Mystik FG2 Grease (5607)	Mystik Oil & Grease #Mystik FG/AW 32 Oil (1931)
	Citgo Oil & Grease #Clarion FG HTEP Grease	Citgo Oil & Grease #Clarion FG AW Oil 32
	Lyondell Lubricants Ideal FG 2 Grease	Lyondell Lubricants #Ideal FG 32 Oil
Exxon Mobil Corp.	Mobil #Mobil Grease FM102	Mobil DTE FM 32 Oil
	Exxon Foodrex FG 1	Exxon *Nuto FG Hydraulic oil 32
76 Lubricants Co.	76 Lubricants 76 Pure FM Grease	76 Lubricants 76 FM Oil 32

*Note: 1. In front of the oil grade means it is suitable for sub zero temperature (F) service.
2. Food machinery lubricants meet USDA H-1 requirements and FDA document 21 CFR 178.3570.
In addition, # in front of the product name means it is NSF 61 registered products.

TROUBLESHOOTING		
TROUBLE	PROBABLE CAUSE	REMEDY
1. Pump does not start	A. Electrical circuit open or not completed B. Improper lateral adjustment. Impeller on bottom. C. Low voltage supplied to electric driver D. Defective motor	Check circuit and correct. Reset impeller adjustment, See page 16. Check whether driver wiring is correct and receives full voltage. Consult factory.
2. No liquid delivered	A. Discharge valve closed B. Speed is too low C. Wrong rotation D. Obstruction in liquid passage E. Water level in the well is below 1 st stage impeller F. Static lift too high G. Field head requirement greater than design head H. Damaged bowl assembly; Broken or disconnected shaft I. Driver with reduced voltage, or reduced current starting does not come up to speed	Be sure the discharge valve is in full open position. Check if driver is directly across the line and receiving full voltage. Check for CCW rotation when viewed from above. Check engagement of motor coupling. Pull pump, inspect suction strainer, impeller and bowls. Increase pump setting by adding column. Check the dynamic water level in well. Consult factory for adding stages or increase impeller diam. Check system friction loss. Increase discharge piping size. Consult factory for adding stages or increase impeller diameter Pull pump and repair all damaged components. Check RPM, voltage and amp's.
3. Not enough liquid	A. Same as items 2-A thru 2-G B. Cavitation C. Impellers adjusted too high D. Air or gas in the water E. Excessive pump wear	Same as items 2-A thru 2-G. Insufficient NPSH available. Consider to low the bowl assembly by adding column. See page 16. If successive starts and stops does not remedy, low pump if possible, or close discharge valve to maintain well pumping level at a lower GPM. Pull pump and repair as required.
4. Not enough pressure	See not enough liquid.	See not enough liquid.
5. Pump works for a while and quits	A. Excessive horsepower required. B. Pumping higher viscosity or specific gravity liquid than designed for. C. Mechanical failure of critical parts D. Suction strainer clogged E. Misalignment F. Break suction	Use larger driver. Consult factory. Test liquid for viscosity and specific gravity. Check bearings and impellers for damage. Any irregularities in these parts will cause a drag on the shaft. Pull pump and clean the strainer. Realign pump and driver Check dynamic water level in the well. Lower bowl assembly by adding column.

TROUBLESHOOTING		
TROUBLE	PROBABLE CAUSE	REMEDY
6. Pump takes too much power	<ul style="list-style-type: none"> A. Damaged impeller B. Foreign object lodged between impeller and bowl C. Specific gravity higher than pump designed for D. Viscosity too high, partial freezing of pumpage E. Defective bearing F. Packing is too tight 	<p>Inspect, replace if damaged. Remove object as required.</p> <p>Test liquid for viscosity and specific gravity. Check for both. They can cause drag on impeller. Replace bearing, check shaft or shaft sleeve for scoring. Release gland pressure. Retighten. (See page 18.) Keep leakage flowing. If no leakage, check packing, sleeve or shaft.</p>
7. Pump is too noisy	<ul style="list-style-type: none"> A. Cavitation B. Bent shaft C. Rotating parts binding, loose or broken. D. Bearings are worn out E. Resonance 	<p>Same as Item 3-B. Straighten as required. See Page 11 for runout limits. Replace as required.</p> <p>Replace bearings. Check piping strain, consult factory.</p>
8. Excessive vibrations	<ul style="list-style-type: none"> A. Coupling misalignment, bent impeller unbalance, worn bearings, cavitation, piping strain and/or resonance B. Motor or gear driveshaft end play maladjustment C. Bent shaft D. Crooked well. 	<p>Determine cause utilizing shaft vibration frequency analyzer and/or pump disassemble. Complex problem may require factory service assistance. See Installation of Hollow Shaft Driver (VHS), Page 15. Straighten as required. See Page 11 for runout limits. Survey the well and consult factory.</p>
9. Pump leaks excessively at stuffing box	<ul style="list-style-type: none"> A. Defective packing B. Wrong type of packing 	<p>Replace worn packing. Replace packing not properly installed or run-in. Replace improper packing with correct grade for liquid being pumped.</p>
10. Stuffing box is overheating	<ul style="list-style-type: none"> A. Packing is too tight B. Packing is not lubricated C. Wrong grade of packing D. Stuffing box improperly packed 	<p>See item 6-F. Release gland pressure and replace all packing if burnt or damaged. Re-grease packing as required. Consult factory. Repack stuffing box.</p>
11. Packing wears too fast	<ul style="list-style-type: none"> A. Shaft or shaft sleeve worn B. Insufficient or no lubrication C. Improperly packed D. Wrong grade of packing 	<p>Pull pump and remachine, or replace shaft and/or sleeve. Repack and make sure packing is loose enough to allow some leakage. Repack properly, make sure all old packing is removed and stuffing box is clean. Consult factory.</p>

Disassembly And Reassembly

DISASSEMBLY

▲ WARNING Before working on pump or motor, lock out driver power to prevent accidental startup and physical injury.

NOTE: Pump components should be match-marked prior to disassembly to ensure they are reassembled in the correct location.

HEAD AND COLUMN

1. On pumps which are driven through a gear drive, remove the driveshaft between the gear and the prime mover.
2. On pumps, which are electric motor driven, remove the electrical connections at the conduit box and tag the electrical leads, so they can be reassembled the same way they were disassembled.
3. Uncouple driver (or gear box) from pump shaft and mounting flanges and lift off by the lifting lugs or eyebolts as furnished.

▲ WARNING Never try to lift entire pump assembly by the lifting lugs or eyebolts furnished for the driver only.

4. Disconnect discharge head from the discharge piping. Remove all hold down bolts and external piping. Remove coupling, packing box and proceed with disassembly down to the bowls by reversing the procedures described in detail for assembling the unit.

BOWL ASSEMBLY

The bowl assembly is composed of a suction bowl/bell, intermediate bowl(s), top bowl, impellers and securing hardware, bearings, and pump shaft.

Turbine bowl impellers are secured to the shaft by either a taperlock or a key and split thrust ring. Follow only those procedures that apply to the particular construction supplied.

NOTE: Match mark bowl assembly in sequence of disassembly to aid in the reassembly procedure.

TAPERLOCK CONSTRUCTION BOWL DISASSEMBLY

1. Remove capscrews that secure top intermediate bowl (669), not shown, to intermediate bowl (670). See Figure 1 or 2.
2. Slide discharge bowl and top bowl off the pump shaft (660).

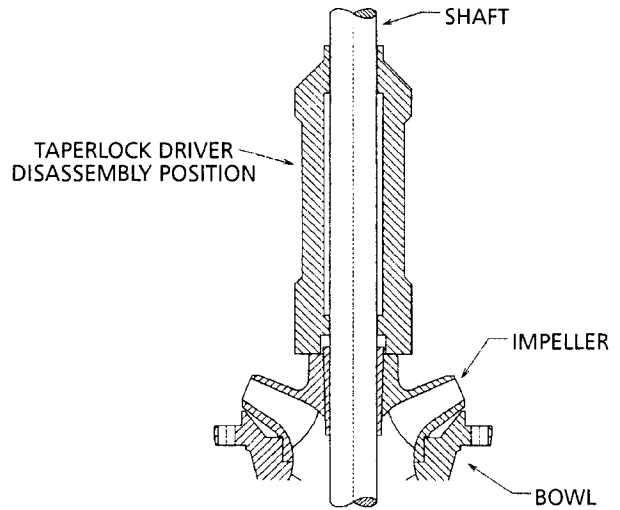

Figure 13

3. Pull shaft out as far as possible and strike Impeller hub by a taperlock driver or equivalent sliding along the pump shaft to drive the impeller off the taperlock (See Figure 12).
4. After the impeller is freed, insert a screwdriver into the slot in the taperlock and spread it open. Slide the taperlock and impeller off the pump shaft.
5. Repeat the above procedures until the bowl assembly is completely disassembled.

TURBINE BOWL – WEAR RING REMOVAL

1. Remove set screws or grind off tack weld, when rings are furnished with those locking methods.
2. Utilizing a diamond point chisel, cut two “V” shaped grooves on the bowl wear ring approximately 180 degrees apart. Use extreme care not to damage the wear ring seat.
3. With a chisel or drift, knock the end of one half of the ring in, and pry the ring out.
4. On special materials such as chrome steel, set up the bowl in a lathe and machine the wear ring off using extreme care not to machine or damage the ring seat.

BOWL AND LINESHAFT BEARING REMOVAL

Utilizing an arbor press and a piece of pipe or sleeve with outside diameter slightly smaller than the outside diameter of the bearing to press the bearing out.

▲ WARNING NOTE: Bowl bearings are press fit. Do not remove unless replacement is necessary.

INSPECTION AND REASSEMBLY

INSPECTION AND REPLACEMENT

1. Clean all pump parts thoroughly with a suitable cleaner.
2. Check bearing retainers for deformation and wear.
3. Check shafts for straightness and excessive wear on bearing surfaces. Average total runout should be less than 0.0005" TIR per foot, not to exceed 0.005" T.I.R. for every 10 feet of shafting.
4. Visually check impellers and bowls for cracks and pitting. Check all bowl bearings for excessive wear and corrosion.
5. Replace all badly worn or damaged parts with new parts. In addition, replace all gaskets and packing as required.

TURBINE BOWL WEAR RING INSTALLATION

Place chamfered face of the bowl or impeller wear ring towards the ring seat and press the ring into the seat. Use an arbor press or equal, making sure the ring is flush with the edge or the wear ring seat.

INSTALL BOWL AND LINESHAFT BEARING

(Refer to Figure 1 for components numbers)

1. Press bearing (653) into retainer (652) using an arbor press or equal.
2. Press bearing (690) into suction bowl/bell (688) hub using an arbor press or equal. The top of the bearing should protrude above the suction hub equal to the depth of the counter bore in the sand collar.
3. Place the bowl (670) with the flange downward and press bearing (672) through chamfered side of bowl hub until the bearing is flush with the hub by using an arbor press or equal.

REASSEMBLY THE BOWL ASSEMBLY OF TAPERLOCK CONSTRUCTION

1. For ease in reassembly apply a thin film of turbine oil to all mating and threaded parts. **Be sure the shaft has been cleaned and checked for straightness.**
2. If the sand collar is not assembled to the shaft, install the sand collar. The sand collar is attached to the shaft with a shrink fit. The larger diameter of the counterbore of the sand collar goes toward the suction bell bearing. Heat the sand collar until it slips over the shaft and quickly position it so that the bottom of the sand collar is set according to the "X" dimension, before it cools. See Figure 13. See Table 1 for the "X" dimensions. Slide the plain end of the pump shaft into the suction bowl/bell bearing until the sand collar rests against the suction bowl/bell hub.

▲ WARNING Wear protective gloves and use appropriate eye protection to prevent injury when handling hot parts.

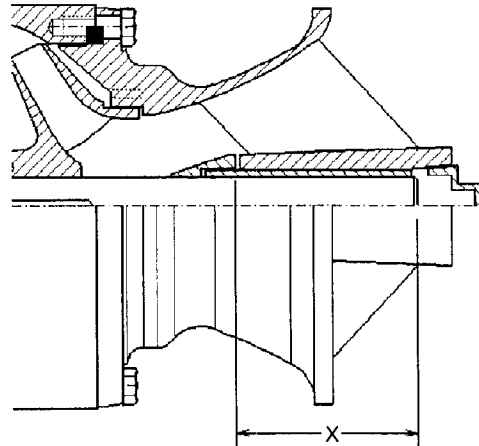

Figure 14

TABLE 1 Sand Collar Location Dimension

Pump Model	"X" Dim.	Pump Model	"X" Dim.
5C, 5T	1.88"	11A, 11RA	5.31"
5RWA	1.81"	11C	4.88"
6A, 6RA	3.13"	11WA	5.13"
6C	2.25"	12C	5.31"
6DH	3.50"	12DH, 12FD	5.19"
7A, 7RA	3.13"	12FR	6.50"
7C, 7T, 7WA	2.81"	12WA, 12RA	5.00"
8A, 8RA	3.13"	12RJ	4.94"
8DH	4.44"	13A, 13RA	7.19"
8RJ	2.88"	13C	5.13"
9A, 9RA	3.41"	14DH	8.13"
9RC, 9T, 9WA	5.19"	14F, 14H, 14RH	7.13"
10A, 10RA	4.31"	14RJ	5.06"
10DH	6.31"	15F Bowl	9.50"
10L	6.25"	16B	6.56"
10RJ	5.00"	16DH Bowl	8.63"
10WA	5.19"	16DM	5.88"
		16RG	6.69"

3. Hold the shaft in this position by inserting a long capscrew (or all thread rod with a hex nut) with an assembly jig into the bottom end of the suction hub and secure tight into the threaded hole at the end of the shaft. **Be sure the shaft has been cleaned and checked for straightness.**
4. Slide the first impeller over the shaft until it seats on the suction bowl/bell.
5. Insert a screwdriver into the slot in the taperlock (677) spread the slot and slide the taperlock over the pump shaft. Hold the impeller against bowl and slide the taperlock into the impeller hub. **Be sure the taperlocks have been cleaned and are dry.**

6. Hold impeller firmly against the suction bowl/bell and drive the taperlock into place with a taperlock driver, (See Figure 14). After the impeller is secured in position, the top end of the taperlock should be 1/8" above the impeller hub.

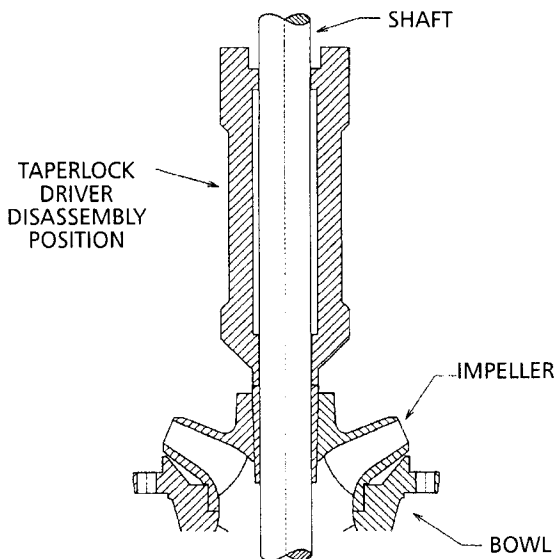

Figure 15

7. Slide intermediate bowl (670) onto shaft and secure with capscrews provided.
8. Repeat preceding procedure for number of stages required.
9. Remove long capscrew and the assembly jig at the end of suction hub and check that the shaft rotates freely without dragging or binding. Also check for adequate lateral (end play).

FINAL ASSEMBLY

After assembly of bowl assembly, reassemble pump as described in "Installation" and also "Startup and Operation Procedures".

Repair Parts

ORDERING PARTS

When ordering spare or replacement parts, the pump serial number, size and type of pump must be given. This can be found on the nameplate furnished with the unit. Give the complete name and reference number of each part as indicated on the applicable sectional drawings, Figure 1 or Figure 2, and the quantity required.

STOCKING SPARE PARTS

Spare parts to be kept in inventory will vary according to service, field maintenance, allowable down time and number of units. A minimum inventory of one complete set of bearings and one spare of each moving part is suggested.

RETURNING PARTS

A completed Return Material Authorization (RMA) form must accompany all materials returned to the factory. The RMA forms can be obtained direct from the factory or through your local Goulds Water Technology representative. The RMA form must be filled in completely and forwarded as directed thereon. Parts being returned under warranty claim must have a complete written report submitted with the RMA form.

CAUTION *Returned material must be carefully packaged to prevent transit damage - the factory cannot assume any responsibility for parts damaged in transit.*

LIMITED WARRANTY

Company warrants title to the product(s) and, except as noted with respect to items not of Company's manufacturer, also warrants the product(s) on date of shipment to Purchaser, to be of the kind and quality described herein, and free of defects in workmanship and material. THIS WARRANTY IS EXPRESSLY IN LIEU OF ALL OTHER WARRANTIES, INCLUDING BUT NOT LIMITED TO IMPLIED WARRANTIES OF MERCHANTABILITY AND FITNESS, AND CONSTITUTES THE ONLY WARRANTY OF COMPANY WITH RESPECT TO THE PRODUCT(S).

If within one year from date of initial operation, but not more than 18 months from date of shipment by Company of any item of product(s), Purchaser discovers that such item was not as warranted above and promptly notifies Company in writing thereof, Company shall remedy such nonconformance by, at Company's option, adjustment or repair or replacement of the item and any affected part of the product(s). Purchaser shall assume all responsibility and expense for removal, reinstallation, and freight in connection with the foregoing remedies. The same obligations and conditions shall extend to replacement parts furnished by Company hereunder. Company shall have the right of disposal of parts replaced by it. Purchaser agrees to notify Company, in writing, of any apparent defects in design, material or workmanship, prior to performing any corrective action back-chargeable to the Company. Purchaser shall provide a detailed estimate for approval by the Company.

ANY SEPARATE LISTED ITEM OF THE PRODUCT(S) WHICH IS NOT MANUFACTURED BY THE COMPANY IS NOT WARRANTED BY COMPANY and shall be covered only by the express warranty, if any, of the manufacturer thereof.

THIS STATES THE PURCHASER'S EXCLUSIVE REMEDY AGAINST THE COMPANY AND ITS SUPPLIERS RELATING TO THE PRODUCT(S), WHETHER IN CONTRACT OR IN TORT OR UNDER ANY OTHER LEGAL THEORY, AND WHETHER ARISING OUT OF WARRANTIES, REPRESENTATIONS, INSTRUCTIONS, INSTALLATIONS OR DEFECTS FROM ANY CAUSE. Company and its suppliers shall have no obligation as to any products which have been improperly stored or handled, or which have not been operated or maintained according to instructions in Company or supplier furnished manuals.

LIMITATION OF LIABILITY – Neither Company nor its suppliers shall be liable, whether in contract or in tort or under any other legal theory, for loss of use, revenue or profit, or cost of capital or of consequential damages, or for any other loss or cost of similar type or for claims by Purchaser for damages of Purchaser's customers. Likewise, Company shall not under any circumstances be liable for the fault, negligence, wrongful acts of Purchaser or Purchaser's employees, or Purchaser other contractors or suppliers.

IN NO EVENT SHALL COMPANY BE LIABLE IN EXCESS OF THE SALES PRICE OF THE PART OR PRODUCT FOUND DEFECTIVE.



Xylem Inc.
PO Box 5487
Lubbock, TX 79408
Phone: 1-806-763-7867
Fax: 1-800-453-4749

www.xyleminc.com/brands/gouldswatertechnology

Goulds is a registered trademark of Goulds Pumps, Inc. and is used under license.

© 2012 Xylem Inc. IMDWTR02 December 2012